

WinMark Pro Application Note

WinMark Pro v6's new Radial Marking property

FH Flyer marking heads and Fenix Flyer Laser Markers running firmware version 2.70 or higher and working with WinMark Pro version 6.0 or higher, support a new feature called Radial Marking. The Radial Marking property gives the marking head, in conjunction with user-supplied motion control, the ability to mark bitmap objects around the circumference of a cylindrical object or to step and raster across a flat surface.

Background information

Most scan heads are designed to mark flat surfaces that are within the focal plane of the head's focusing lens. Variations in surface flatness or surfaces that are not parallel to the lens compromise the accuracy of beam placement on the part surface. For example, as surface curvature increases steeply away from the focal plane, focused spot size begins to increase and the beam's incident angle increases to a point where mark segments become elongated along the beam path.

Traditionally, marking an image on a curved surface or cylinder requires the user to break an image into individual sections, or tiles, to minimize the distortion of each tile. The curved surface or cylinder is then marked section by section, while carefully positioning the cylindrical surface between marks to 'stitch' the image together. Even a three-axis scan head that compensates for surface curvature, can, at best, only mark approximately 120° around a cylinder. For marks designed to wrap completely around an object, you would still need to tile the image and then carefully reposition the cylinder to stitch the image together.

The WinMark Pro/Flyer implementation works with a user-supplied motion control system, like a stepper system, and input/output (I/O) signals to mark raster images around cylindrical objects. This is accomplished by marking a single raster line at a time while using I/O signals between the Flyer/Fenix Flyer head and parts handling equipment to coordinate marking and part rotation. Because each raster line is positioned in the same area of the mark field, there is no distortion throughout the image, even if it wraps completely around the object.

How radial marking works

Once a mark file containing a bitmap image is created and the Radial Marking property is enabled, marking begins one raster line at a time. After each line is marked, a Flyer output signals parts handling equipment that a raster line is complete. The parts handler then rotates the object by one step and signals a Flyer input to begin another scan line. This handshaking sequence continues until the bitmap is completely marked. While this seems to be a time-consuming process, I/O and part movement occurs quickly, so there is very little difference in actual process time compared to standard marking.

To view a video showing an example of radial marking, check the SYN RAD web site at: http://www.synrad.com/Applications/video_clips.htm and look for the video titled "Marking PVC Around a Circumference" on the playlist.

Radial marking equipment setup

Equipment guidelines

The user must install a rotary mechanism under the marking head with the long axis of rotation centered under the focusing lens, at the point of focus as shown in Figure 1.

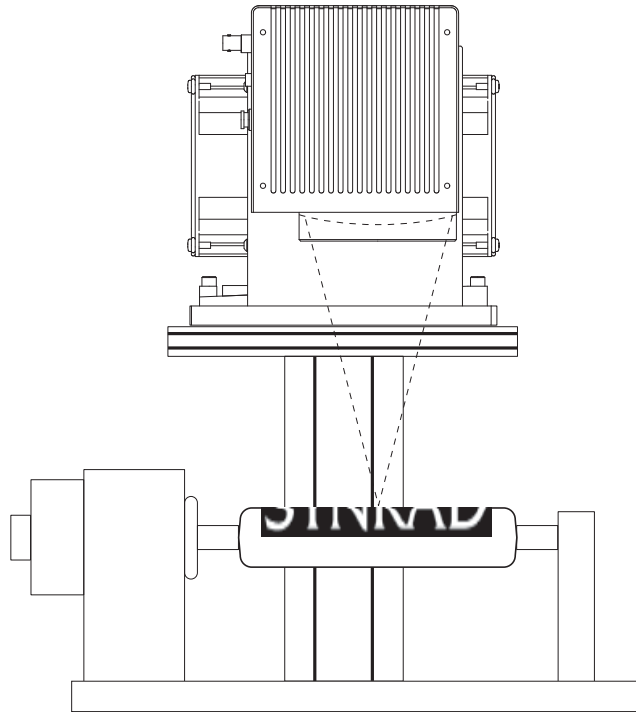

Figure 1 Rotary stepper mechanism positioned under Flyer marking head

The drive mechanism must be able to rotate incrementally in discrete steps that relate to the focused spot size. For example, when using a 200 mm lens, each rotational step must be 0.011" (0.29 mm).

To interface with the Flyer/Fenix Flyer head, the control system for the drive mechanism must have at least two dedicated inputs and two dedicated outputs that operate in the range of 5.0 V–24.0 VDC.

The parts handling controller must provide a 'start mark' output to Flyer input *IN0* and a 'part moving' output to Flyer input *IN4*. The Flyer/Fenix Flyer marker will provide a 'move part' output on *OUT4* and a 'step command' output on *OUT5* to your parts handling inputs.

WinMark Pro–Flyer/Fenix Flyer setup

Mark file setup

After the rotary control system is complete, perform the following steps to configure WinMark Pro and the Flyer/Fenix Flyer marking head for radial marking:

- 1 Open (or create) a mark file containing an imported bitmap object.
- 2 With the *Drawing* object selected, click the *Automation* tab and setup the normal WinMark automation loop using *IN0* and *OUT4* on the Flyer head as described in the *WinMark Pro User's Guide*.
- 3 Select the bitmap object, click the *Format* tab and set the Radial Marking property to *Yes*.
- 4 Click the Part Moving Input property and click the arrow button. In the drop-down list, click *IN4* and choose *Set* (see Figure 2). One raster line in the bitmap is marked each time this Flyer input transitions from an active (*Set*) to inactive (*Clear*) state.

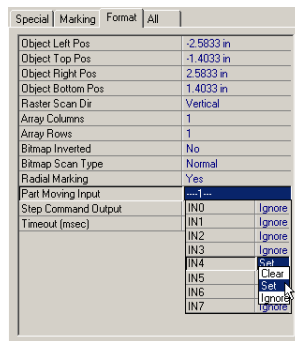

Figure 2 Configure the Part Moving Input property

- 5 Click the Step Command Output property and click the arrow button. In the drop-down list, click *OUT5* and choose *Set* (Figure 3). When *Set* (active), this Flyer output signals parts handling equipment to rotate the part one step.

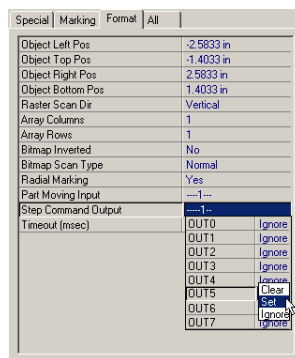

Figure 3 Configure the Step Command Output property

- 6 Click the Timeout (msec) property and enter a value for WinMark to wait until the next input (*IN4*) state change (enter -1 to wait indefinitely). When a Step Command Output transition occurs, the Part Moving Input must also transition within the specified timeout period or the mark session will abort.

Standard automation flowchart

Figure 4 illustrates the standard WinMark Pro Automation Flowchart. Radial marking and its corresponding automation occur within the Mark stage.

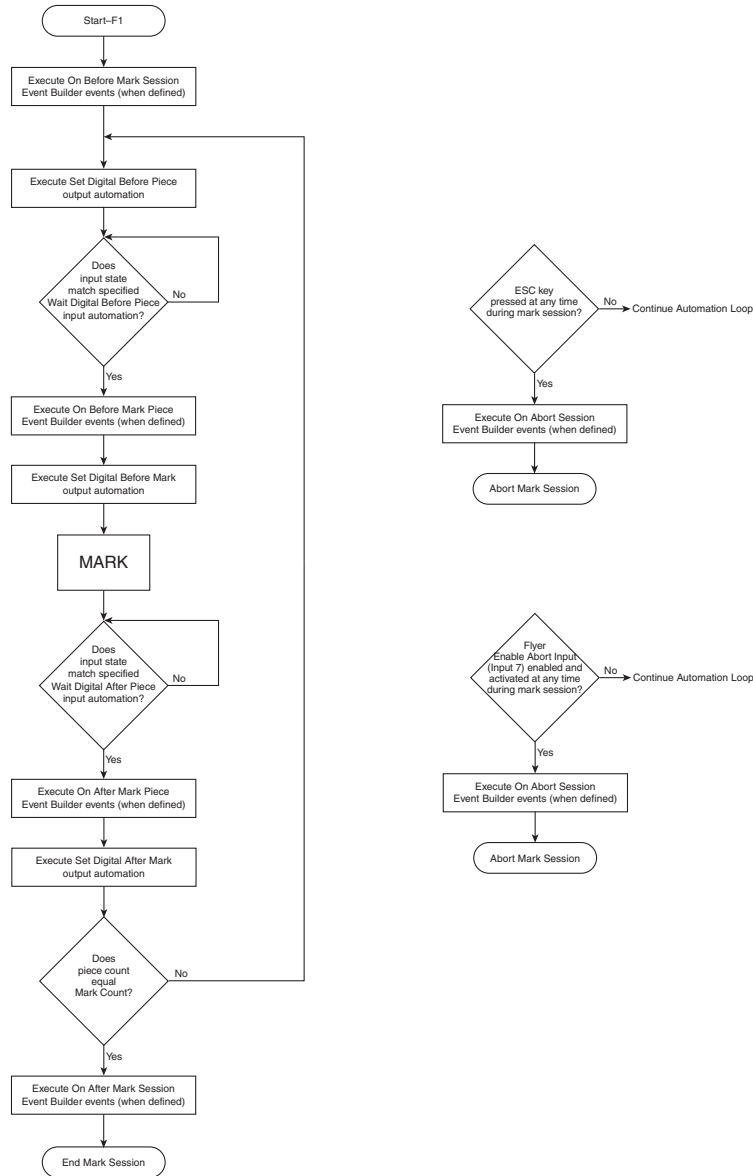

Figure 4 WinMark Pro Automation Flowchart

When a mark session begins, WinMark begins the standard automation loop by executing On Before Mark Session Event Builder events and continues through Set Digital After Mark outputs before checking if the current piece count equals the Mark Count property value. If not, WinMark begins executing at the Set Digital Before Piece stage again. When piece count equals Mark Count, WinMark executes On After Mark Session events and ends the mark session. Each pass through the automation loop results in a single part (or array of parts) being marked.

Radial marking flowchart

The difference between radial marking and standard parts marking is that radial marking automation runs completely within the Mark stage of automation and does not exit until the bitmap image is completely marked or the session is aborted (Figure 5). Each pass through this loop results in a single raster line being marked. After the last raster line is marked, WinMark exits the Mark stage and continues with the next automation stage—Wait Digital After Piece.

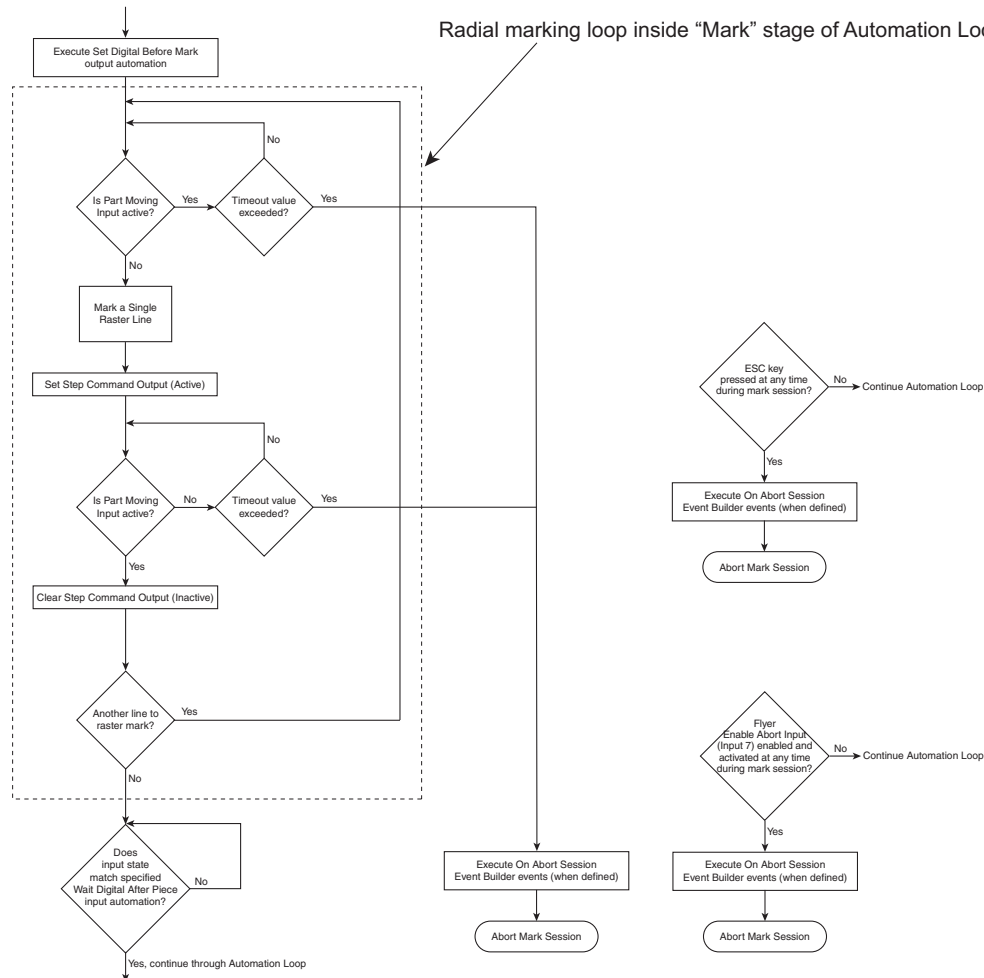

Figure 5 Radial marking flowchart

Figure 6 shows a state, or timing, diagram based on the radial marking flowchart. Use the flowcharts and state diagram to follow through the mark sequence described below.

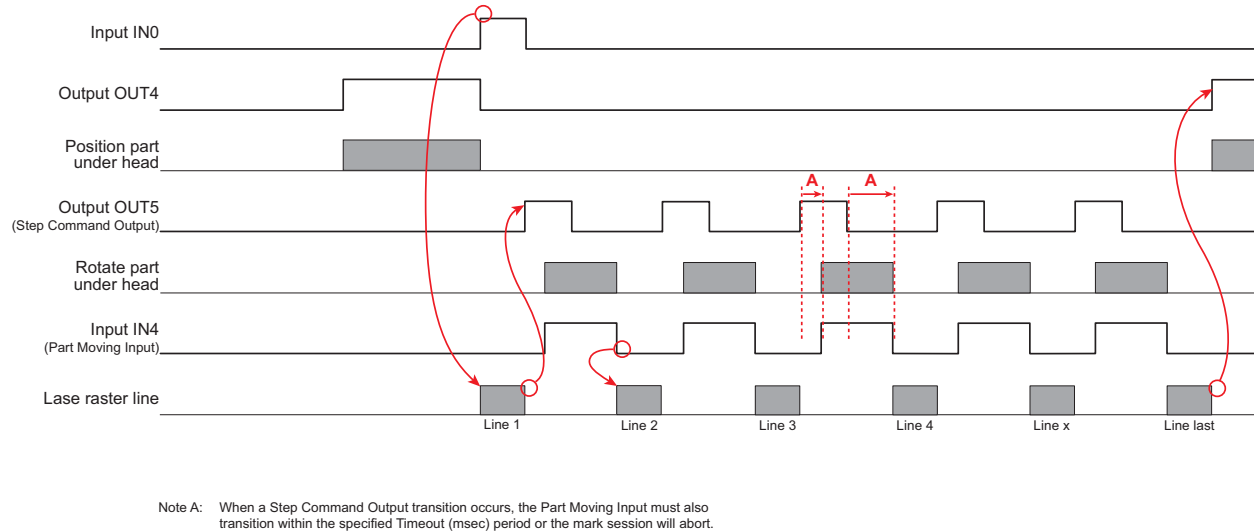

Figure 6 Radial marking state diagram

When a radial marking mark session starts (by pressing F1 or clicking the *Start-F1* button), WinMark Pro begins the standard automation loop by executing On Before Mark Session Event Builder events, when defined.

At the next stage, Set Digital Before Piece, output *OUT4* is *Set* (active) to signal parts handling equipment to move a part into position for marking.

WinMark then pauses at the Wait Digital Before Piece step until the parts handler *Sets* (activates) Flyer input *IN0*, which signals the part is positioned and lasing can begin.

Next, any defined On Before Mark Piece Event Builder events are executed.

In this next stage, Set Digital Before Mark, WinMark *Clears* Flyer output *OUT4* to signal the parts handler that lasing will begin.

Immediately on entry to the Mark stage, WinMark checks Flyer's designated Part Moving Input (input *IN4* in this example). If the input is *Set* (active), WinMark verifies the Timeout (msec) value has not been exceeded; if the Part Moving Input is *Clear* (inactive; meaning that part rotation has halted), then the first raster line in the bitmap image is marked.

After completion of the raster line, Flyer's designated Set Command Output (output *OUT5* in this example) is *Set* active to indicate part rotation can begin.

WinMark checks Flyer's Part Moving Input (*IN4*). If *Set* (active), then part movement is occurring and WinMark *Clears* Flyer's Set Command Output to reset the 'rotate part' signal. If input *IN4* is *Clear* (inactive), WinMark verifies the Timeout (msec) value has not been exceeded.

If the bitmap image contains another unmarked raster line, WinMark loops back to wait for the Part Moving Input *IN4* to toggle from a *Set* (active) to *Clear* (inactive) state and then marks another raster line. These steps within the Mark stage of WinMark's automation loop continue until the last raster line is lased.



When the last raster line in the image is marked, WinMark (at the Wait Digital After Piece step) verifies that input (*INO*) was cleared during the mark. Parts handling equipment can *Clear INO* anytime after it “sees” output *OUT4* go *Clear* (inactive) on entry into the Mark stage.

WinMark proceeds to execute any On After Mark Piece Event Builder events and then, in the Set Digital After Mark step, WinMark *Sets* Flyer output *OUT4* to signal parts handling to remove the previous piece and position the next piece for lasing. If the piece count does not equal the Mark Count property, WinMark loops back to the Set Digital Before Piece stage and prepares to mark another part. If the piece count equals Mark Count, WinMark executes any defined On After Mark Session events and then ends the mark session.

In a radial marking automation loop, as well as in the standard automation loop, WinMark Pro will immediately execute any defined On Abort Session Event Builder events and then abort the mark session if the ESC key is pressed or if Flyer’s Enable Abort Input (Input 7) property was previously enabled and is now active.

For further information, contact SYN RAD at 1.800.796.7231; outside the U.S., dial +1.425.349.3500 or fax us at +1.425.349.3500. Send email to: support@synrad.com.