

# SYNRAD Technical Bulletin

# 018

Technical Issue: Difference in DB-9 Pin Configuration Between Firestar ti-Series Lasers versus t-Series/t70i Lasers

Date: 09 March 2010

Models Affected: ti-Series SA Models Only. All ti-Series fan-cooled (KF/SF) and water-cooled (KW/SW) models are unaffected

## Description:

The pinout and functionality of the side-mounted DB-9 connector on **ti-Series** SA model lasers is **not** the same as the DB-9 connector on t-Series or t70i SA model lasers. Firestar ti60 OEM air-cooled (SA) model lasers incorporate a side-mounted DB-9 connector that provides several functions including supplying power for customer-supplied 48 VDC cooling fans. The DB-9 pin configuration was substantially changed from the configuration used on Firestar t-Series and t70i SA model lasers. Updated configuration information is available in ti-Series operator's manuals created on or after version 1.2, dated March 2010.

This Bulletin provides the correct DB-9 pinout/signal descriptions as described in version 1.2 of the *Firestar ti-Series Operator's Manual* ([http://www.synrad.com/Manuals/manuals\\_laser.htm](http://www.synrad.com/Manuals/manuals_laser.htm)).

## Firestar ti60 DB-9 pin descriptions

The side-mounted DB-9 connector on SA model lasers provides a *Shutter Switch* input, auxiliary +5 V power, and +48 VDC for powering user-supplied 48 V cooling fans. Figure 1 illustrates DB-9 pinouts and Table 1 describes the function of each pin on the DB-9 connector.

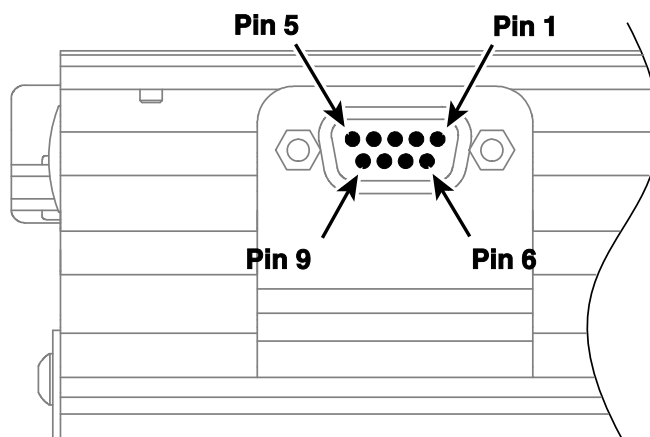

Figure 1 DB-9 connector pinouts

**Table 1 Side-mounted DB-9 pin descriptions**

<b>Pin</b>	<b>Function</b>	<b>Description</b>
1	No Connection	
2	Shutter Switch	In <i>Keyswitch</i> models, this input connects to the physical <i>Shutter Switch</i> . Leave this input open to enable lasing. Grounding this pin indicates that the shutter is Closed, which disables lasing. If connecting an external shutter switch to Pin 2, the circuit path must be grounded to Pin 6 or Pin 7, Signal Ground. There is a five-second delay imposed from the time the shutter input is opened to the time that PWM Command signals are accepted.
3	+5 VDC Auxiliary Power	This output provides +5 V for driving external inputs or outputs (like a diode pointer). The +5 VDC Auxiliary Power output (Pin 3) is protected by a 0.5 A self-resetting fuse. The return (ground) path is through Pin 6 or Pin 7, Signal Ground.
4	Fan Power, +48 VDC	This output provides +48 VDC for powering a customer-supplied cooling fan. The Fan Power, +48 VDC output (Pin 4) is sourced directly from the user's 48 VDC power supply and is protected by a 1.1 A self-resetting fuse. Pin 4 and Pin 8 can only source a <b>combined</b> current of 1.0 A total.
5	Fan Power Return	This connection provides a return (ground) path for Pin 4 and Pin 8 (Fan Power, +48 VDC). Pin 5 and Pin 9 (Fan Power Return) can only sink a <b>combined</b> current of 1.0 A total. Internal circuitry allows the laser to control fan speed based on the laser's output power and chassis temperature. See <i>48 VDC fan speed control</i> for detailed information.
6, 7	Signal Ground	Pin 6 and Pin 7 provide a return (ground) path for Pin 2 (Shutter Switch), Pin 3 (+5 VDC Auxiliary Power), or Pin 5/Pin 8 (Fan Power, +48 VDC) when fan speed control is not required. Pin 6 and Pin 7, Signal Ground, are the only DB-9 pins connected to chassis ground. Do not use these pins if DC power is supplied from an external customer-supplied DC power source.
8	Fan Power, +48 VDC	This output provides +48 VDC for powering a customer-supplied cooling fan. The Fan Power, +48 VDC output (Pin 8) is sourced directly from the user's 48 VDC power supply and is protected by a 1.1 A self-resetting fuse. Pin 4 and Pin 8 can only source a <b>combined</b> current of 1.0 A total.
9	Fan Power Return	This connection provides a return (ground) path for Pin 4 and Pin 8 (Fan Power, +48 VDC). Pin 5 and Pin 9 (Fan Power Return) can only sink a <b>combined</b> current of 1.0 A total. Internal circuitry allows the laser to control fan speed based on the laser's output power and chassis temperature. See <i>48 VDC fan speed control</i> for detailed information.

### 48 VDC fan speed control

The side-mounted DB-9 connector on SA model lasers has internal circuitry that controls fan speed based on the laser's output power and chassis temperature. At tickle, or very low PWM duty cycles, cooling fans run at reduced speed to minimize noise; at higher PWM duty cycles, fan speed increases to match the cooling rate to power output. Fan speed is controlled by pulse width modulation (PWM) of the Fan Power Return lines (Pin 5/Pin 9) as shown in Figure 2.

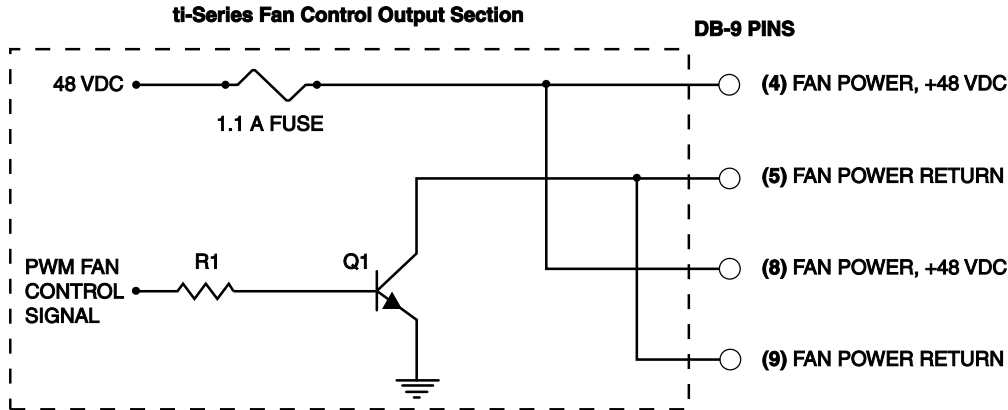

Figure 2 Internal fan speed control circuitry

Figure 3 illustrates the connections for fan speed control when using customer-supplied 48 VDC cooling fans. Connect the positive (+) fan lead to Pin 4 or Pin 8, Fan Power, +48 VDC, and connect the negative (-) fan lead to Pin 5 or Pin 9, Fan Power Return. If fan speed control is not desired, connect the negative (-) fan leads to Pin 6 or Pin 7, Signal Ground.

**Important Note:** The total current draw of *both* fans must not exceed 1.0 A to prevent tripping the internal 1.1 A self-resetting fuse.

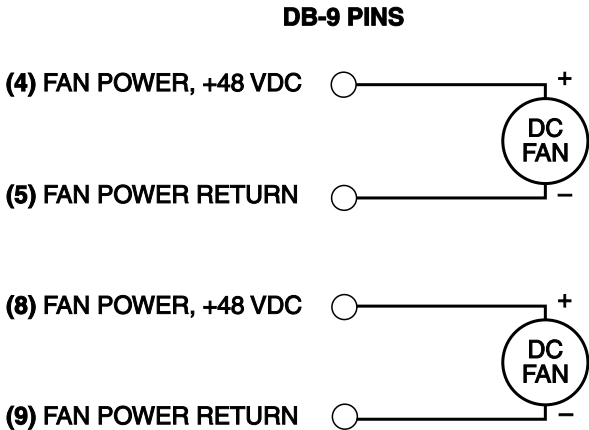
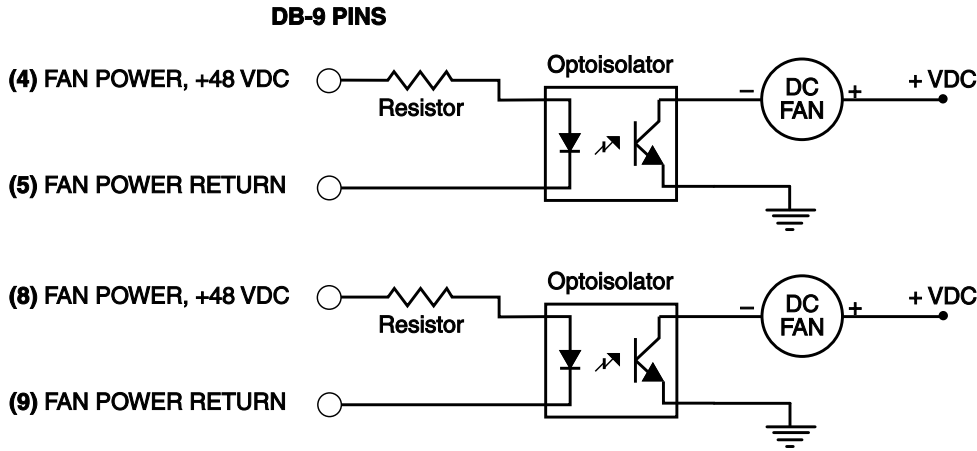

Figure 3 48 VDC fan connections

**Note:** Some types of cooling fans are not designed for PWM control and will stall at low speeds. SYNRAD has tested Delta EFB1248SHE cooling fans with good results.

**Isolated cooling fan connections**

To connect cooling fans operating at voltages other than 48 VDC or with currents greater than 1.0 A, a customer-designed isolation circuit like that shown in Figure 4 could power almost any type of DC cooling fan (with a suitably sized resistor and optoisolator device) while minimizing voltage or current spikes that might damage the laser’s control board.



**Figure 4 Alternate fan connections**

For further information contact SYNRAD at 1.800.796.7231; outside the U.S., dial +1.425.349.3500 or fax us at +1.425.349.3667.