

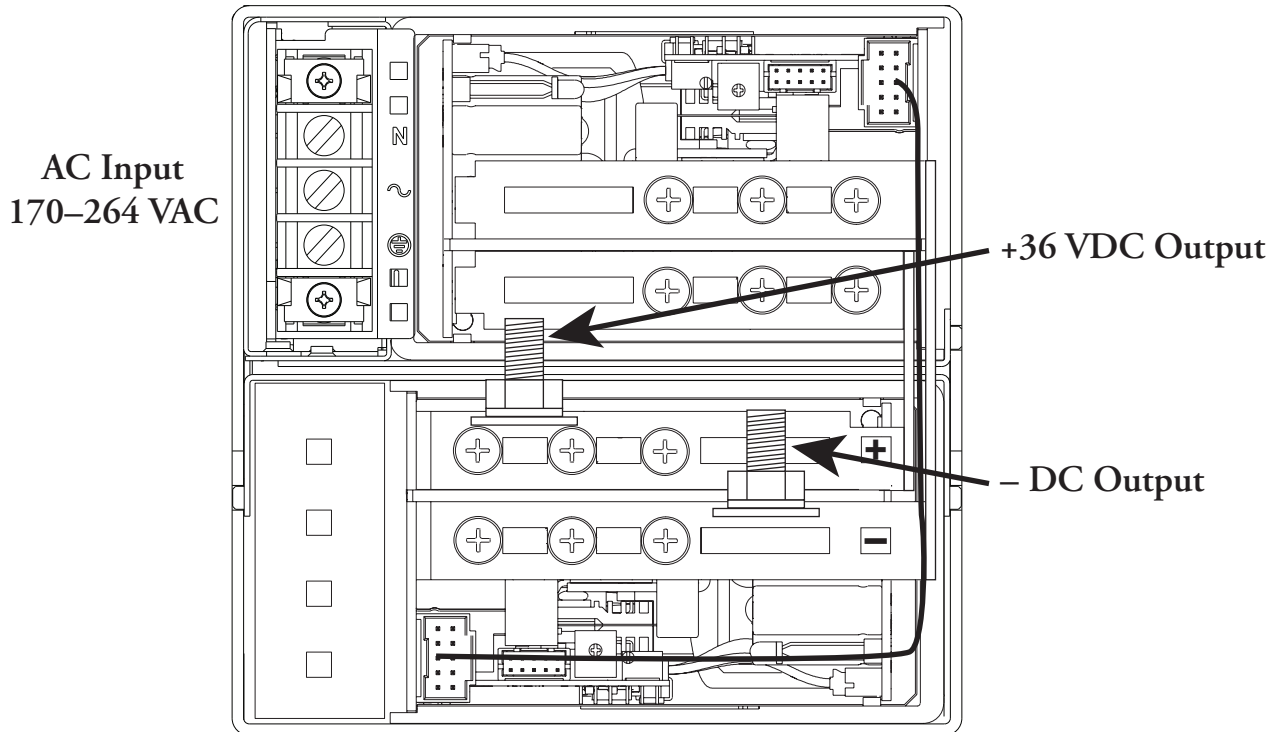

SYNRAD PS-36 DC Power Supply (Astec Emerson iVS1-5U0-5U0-60-A)



AC Input Connections:

- * Connect AC Neutral to terminal labeled "N".
- * Connect AC Line (Hot) to terminal labeled "~".
- * Attach AC safety ground (earth) to terminal labeled "⊕".

DC Output Connections:

- * Connect DC Positive (red wire) to Positive (+) 36 VDC terminal post.
- * Connect DC Return (black wire) to Negative (-) terminal post.

Rev 1 / 08 Sept 2010
P/N 900-20172-01

Intelligent VS Power

Up to 4920 Watts

Total Power: Up to 4920 Watts
Input Voltage: 85 - 264 Vdc
120 - 300 Vdc
of Outputs: Up to 24

Special Features

- Full medical EN60601 approval
- Intelligent I²C control
- Voltage adjustment on all outputs (manual or I²C)
- Configurable input and output OK signals and indicators
- Configurable inhibit/enable
- Configurable output UP/DOWN sequencing
- High power density (12 W/cu-in)
- Intelligent fan (speed control/fault status)
- uP controlled PFC input with active Inrush protection
- I²C monitor of voltage, current, and temperature
- Programmable voltage, current limit, inhibit/enable through I²C
- Optional extended hold-up module (SEMI F47 compliance)
- Increased power density to 150%
- Optional conformal coating
- Industrial temp range (-40 °C to 70 °C)
- Uses standard iMP modules
- Field upgradeable firmware
- RoHS compliant

Safety

- **UL** UL60950/UL2601
- **CSA** CSA22.2 No. 234 Level 5
- **VDE** EN60950/EN60601-1
- **BABT** Compliance to EN 60950/EN60601 BS 7002
- **CB** Certificate and report
- **CE** Mark to LVD

iVS™



Electrical Specifications

Input	
Input range:	
iVS1 & iVS3	90 - 264 Vac 1Ø; 120 - 300 Vdc
iVS6 & iVS8	170 - 264 Vac 3Ø
iVS8H	480 Vac nominal 3Ø 380 Vac nominal 3Ø derate to 3800 W max.
Frequency:	47 - 440 Hz
Inrush current:	40 A peak maximum (soft start)
Efficiency:	Up to 85% @ full case load
Power Factor:	0.99 typ. meets EN61000-3-2
Turn-on time:	AC on 1.5 sec typical, inhibit/enable 150ms typical Programmable; 50ms internal turn-on delay (Dual Output only)
EMI Filter:	CISPR 22/EN55022 Level "B"
Leakage current:	500 µA max. @ 240 Vac; 47-63 Hz
Radiated EMI:	CISPR 22/EN55022 Level "B"
Holdover storage:	10 ms minimum (independent of input Vac) additional 20mSEC holdover storage with optional HUP module (SEMI F47 compatible)
AC OK:	>5ms early warning minutes before outputs lose regulation Full cycle ride thru (50 Hz). Programmable
Harmonic distortion:	Meets EN61000-3-2
Isolation:	Meets EN60950 and EN60601
Global inhibit / enable:	TTL, Logic "1" and Logic "0"; configurable
Warranty:	3 years



Output	
Adjustment range:*	± 10% minimum all outputs (manual) (full module adjustment range using I ² C)
Factory set point accuracy:	1%
I ² C output program accuracy:	± 5%
Margining:	± 4 - 6% nominal analog (single output module only)
Overall regulation:	0.4% or 20 mV max. (1500 W modules 1% max.)
Ripple:	RMS: 0.1% or 10 mV, whichever is greater Pk-Pk: 1.0% or 50 mV, whichever is greater Bandwidth limited to 20 MHz
Dynamic response:	< 2% or 100 mV, with 25% load step
Recovery time:	To within 1% in < 300 µsec
Overcurrent protection:**	Configurable through I ² C (calibration required). Single output module and main output of the dual output module 105-120% of rated output current. Aux output of dual output module 105-140% of rated output current. Special programmable OCP delay on 1500 W module from 100 mSec to 25.5 seconds with shutdown features.
Short-circuit protection:	Protected for continuous short-circuit. Recovery is automatic upon removal of short (Shutdown mode on 1500 W module).
Overvoltage protection:*	Configurable through I ² C
Single output module:	2 - 5.5 V 122 - 134% ; 6 - 60 V 110 - 120%
Dual output module:	2 - 6 V 122 - 134% ; 8 - 28 V 110 - 120%
Triple output module:	No overvoltage protection provided
Thermal protection:*	Configurable through I ² C All outputs disabled when internal temp exceeds safe operating range. > 5ms warning (AC OK signal) before shutdown
Remote sense:	Up to 0.5 V total drop (not available on triple output module)
Single wire parallel:	Current share to within 2% of total rated current
DC OK:*	+/-5% of nominal. Configurable through I ² C
Minimum load:	Not required
Housekeeping bias voltage:	5 Vdc @1.0 A max. present whenever AC input is applied
Module inhibit:*	Configured and controlled through I ² C
Output/Output isolation:	> 1 Megohm, 500 V
* Can be controlled via I ² C	
** Controlled via I ² C but requires load calibration (except 1500 W module)	

Environmental Specifications

Operating temperature:	-40 ° to 70 °C ambient. Derate each output 2.5% per degree from 50 ° to 70 °C. (-20 °C start up)
Storage temperature:	-40 °C to 85 °C
Electromagnetic susceptibility:	Designed to meet EN61000-4; -2, -3, -4, -5, -6, -8, -11 Level 3
Humidity:	Operating; non-condensing 10% to 95% RH
Vibration:	IEC68-2-6 to the levels of IEC721-3-2
MTBF demonstrated:	> 550,000 hours at full load, 220 Vac and 25 °C ambient conditions

Output Module Line-up

Module Code	1	2	3	5	4	—
Module Type	Single	Single	Single	Single	Dual	Triple
Max output power	210 W	360 W	750 W	1500 W	144 W	36 W
Max output current	35 A	60 A	150 A	140 A	10 A	2 A
Output voltages available*	2-60 V	2-60 V	2-60 V	6-60 V	8 - 15*, 24 - 28; 8 - 15*, 8 - 15*; 8 - 15*, 2 - 6; 2 - 6, 2 - 6; 24 - 28, 24 - 28; 24 - 28, 2 - 6	8-15, 8-15, 2-6; 8-15, 8-15, 8-15; 8-15, 8-15, 18-28; 8-15, 18-28, 2-6
Standard voltage increments	25	25	25	18	16	18
Remote sense	Yes	Yes	Yes	Yes	Yes	No
Remote margin	Yes	Yes	Yes	Yes	No	No
V-Program - I ² C Control	Yes	Yes	Yes	Yes	Yes	No
Active Current Share	Yes	Yes	Yes	Yes	Yes	No
Module Inhibit - I ² C Control	Yes	Yes	Yes	Yes	Yes	Yes
Module Inhibit - Analog	Yes	Yes	Yes	Yes	Yes	No
Overvoltage/Overcurrent protection	Yes	Yes	Yes	Yes	Yes	Yes
Minimum load required	No	No	No	No	No	No
Slots occupied in any iVS case	1	2	3	4	1	1

* Note: Contact Factory for extended range down to 6 V

Single



210 W



750 W



360 W



1500 W



144 W



36 W

Dual

Triple

Output Module Voltage/Current*

Voltage	Voltage Code	Single Output Module Code				Dual Output***		Triple Output			I ² C Adjustment Ranges****
		1	2	3	5	4	4	-	-	-	
2 V	A	35 A	60 A	150 A	—	10 A	10 A	—	—	2 A	1.8 - 2.2
2.2 V	B	35 A	60 A	150 A	—	10 A	10 A	—	—	2 A	2.0 - 2.4
3 V	C	35 A	60 A	150 A	—	10 A	10 A	—	—	2 A	2.7 - 3.3
3.3 V	D	35 A	60 A	150 A	—	10 A	10 A	—	—	2 A	3.0 - 3.6
5 V	E	35 A	60 A	150 A	—	10 A	10 A	—	—	2 A	4.5 - 5.5
5.2 V	F	35 A	60 A	144 A	—	10 A	10 A	—	—	2 A	4.7 - 5.7
5.5 V	G	34 A	58 A	136 A	—	10 A	10 A	—	—	2 A	5.0 - 6.1
6.0 V	H	23 A	42 A	97.5 A	140 A	10 A*	10 A*	—	—	2 A	5.4 - 6.6
8.0 V	I	20 A	36 A	84.4 A	140 A	10 A	4 A	1 A	1 A	1 A	7.2 - 8.8
10 V	J	18 A	32 A	75 A	140 A	10 A	4 A	1 A	1 A	1 A	9.0 - 11.0
11 V	K	17 A	31 A	68 A	136.3 A	10 A	4 A	1 A	1 A	1 A	9.9 - 12.1
12 V	L	17 A	30 A	62.5 A	125 A	10 A	4 A	1 A	1 A	1 A	10.8 - 13.2
14 V	M	14 A	21 A	53.5 A	107 A	9 A	4 A	1 A	1 A	1 A	12.6 - 15.4
15 V	N	14 A	20 A	50 A	100 A	8 A	4 A	1 A	1 A	1 A	13.5 - 16.5
18 V	O	11 A	19 A	41.6 A	83.3 A	—	—	—	0.5 A	0.5 A	16.2 - 19.8
20 V	P	10.5 A	18 A	37.5 A	75 A	—	—	—	0.5 A	0.5 A	18.0 - 22.0
24 V	Q	8.5 A	15 A	30 A	62.5 A	4 A	2 A	—	0.5 A	0.5 A	21.6 - 26.4
28 V	R	6.7 A	11 A	26.8 A	53.5 A	3 A	2 A	—	0.5 A	0.5 A	25.2 - 30.8
30 V	S	6.5 A	11 A	25 A	50 A	—	—	—	—	—	27.0 - 33.0
33 V	T	6.2 A	10.9 A	22.7 A	35.8 A	—	—	—	—	—	29.7 - 36.3
36 V	U	5.8 A	10 A	20.8 A	35.8 A	—	—	—	—	—	32.4 - 39.6
42 V	V	4.2 A	7.5 A	16 A	35.7 A	—	—	—	—	—	37.8 - 46.2
48 V	W	4.0 A	7.5 A	15.6 A	31.2 A	—	—	—	—	—	43.2 - 52.8
54 V	X	3.7 A	6.0 A	13.9 A	27.7 A	—	—	—	—	—	48.6 - 59.4
60 V	Y	3.5 A	6.0 A	12.5 A	25 A	—	—	—	—	—	54.0 - 66.0

Contact Factory

Special*	Z	35 A	60 A	150 A	—	—	10 A				2.3 - 2.6
Special*	Z	35 A	60 A	150 A	—	—	10 A				3.7 - 4.4
Special*	Z	20 A	36 A	80 A	140 A	—	8 A				6.7 - 7.1

* Note: Contact Factory for extended range down to 6 V.

** Increments of current not shown can be achieved by paralleling modules (add currents of each module selected).

*** Total output power on dual model must not exceed 144 W.

**** For single output modules only.

Ordering Information

Sample below is 3210 W case with 12 V @ 125 A; 24 V @ 8.5 A; 5 V @ 60 A; 12 V @ 10 A and 12 V @ 4 A; with no options.

Case Size	Module/Voltage/Option Codes	Case Option Codes	Software Code	Hardware Code
iVS1	5L1 - 1Q1 - 2EO - 4LLO	00	A	###
Case Size (mm) 1-Phase Input 1 = 5" x 5" x 11"; 1500 W - 3210 W, 9 Slots (127 x 127 x 279.4) 3 = 5" x 8" x 11"; 1800 W - 4500 W, 14 Slots (127 x 203.2 x 279.4) 3-Phase Input 6 = 5" x 5" x 11"; 3120 W, 9 Slots (127 x 127 x 279.4) 8 = 5" x 8" x 11"; 4920 W, 14 Slots (127 x 203.2 x 279.4) 8H = 5" x 8" x 11"; 4920 W, 14 Slots (127 x 203.2 x 279.4)	Module Codes: (None) = 36 W triple O/P (1 slot) 1 = 210 W single O/P (1 slot) 2 = 360 W single O/P (2 slot) 3 = 750 W single O/P (3 slot) 5 = 1500 W single O/P (slot 4) 4 = 144 W dual O/P (1 slot) HUP = Extra 30mS hold-up (1 slot) Voltage Codes: See Output Module Voltage/Current table Option Codes: 0 = Standard 1 = Module enable 2 = Constant current 3 = 1 & 2 combined 4 = Set for use in standard (non-intelligent case) 5 = Shutdown mode for 1500 W 6 = 1 & 5 combined 7-9 Future	First Digit 0 - 9 = Parallel code (See parallel codes table below) Second Digit 0 = No options 1 = Reverse air 2 = Not used 3 = Global enable 4 = Fan Off w/inhibit 5 = Opt 1 + Opt 3 6 = Opt 1 + Opt 4 7 = Opt 3 + Opt 4 8 = Opt 1 + 3 + 4 9 = CANBUS/RS485 73-544-001 B = USB 73-546-001 M = Medical N = M + 1 P = M + 3 R = M + 1 + 3	Software code used for configuration change. "A" is standard	Factory assembled for hardware of firmware mods.
Ordering Note: 1. USB to I ² C module order code 73-769-001				

Parallel Code	Slot No.	iVS1, 6		iVS3, 8, 8H	
		Diagram	Possible Configurations	Diagram	Possible Configurations
1	1 & 2		210 210; 210 144; 144 144		210 210; 210 144; 144 144
2	2 & 3		360 360; 360 210; 360 144; + above		360 360; 360 210; 360 144; + above
3	3 & 4		750 360; 750 210; 750 144; 210 210; 210 144; 144 144		750 750; 750 360; 750 210; 750 144; 210 210; 210 144; 144 144
4	4 & 5		1500 210; 1500 144; 210 210; 210 144; 144 144; 360 210; 360 144		1500 1500; 1500 750; 1500 360; 1500 210; 1500 144; 210 210; 210 144; 144 144; 360 360; 360 210; 360 144
5	3, 4, & 5		750 210 210; 750 210 144; 750 144 144		750 210 210; 750 210 144; 750 144 144
6	iVS1,6: 4 & 6		1500 1500; 1500 750		
7	4, 5, & 6		1500 210 210; 1500 210 144; 1500 144 144		1500 210 210; 1500 210 144; 1500 144 144
8	iVS1,6: 3 & 6 iVS3,8,8H: 4, 5, & 9		750 750		1500 1500 1500; 1500 1500 750; 1500 1500 360; 1500 1500 210; 1500 1500 144
9	iVS1,6: 1 & 6 iVS3, 8, 8H: 4, 5 & 9; 12 & 13		1500 1500; 1500 360; 1500 144		1500 1500 1500 360; 1500 1500 1500 210; 1500 1500 1500 144
A	iVS1,6: 3 & 4; 8 & 9 iVS3, 8, 8H: 4 & 5; 11 & 12		750 210 & 750 210		1500 1500 & 750 750
C	iVS1,6: 3, 4 & 6 iVS3, 8, 8H: 6 & 7; 3, 4, 11 & 12		750, 360, 750		750 750 360 750 750
E	iVS1,6: 3, 4, 6; 8 & 9 iVS3, 8, 8H: 3, 4, 11, & 12		750, 360, 750, 210		750 750 750 750
F	iVS3, 8, 8H: 3 & 4; 11 & 12				750 360 & 750 210; 750 750 & 750 750
G	iVS3, 8, 8H: 3, 4 & 9				750 750 750
H	iVS3, 8, 8H: 11 & 12				750 750
J	iVS3, 8, 8H: 4 & 5; 9 & 10				1500 210 & 210 1500

iVS Case Specifications

iVS1 and iVS6

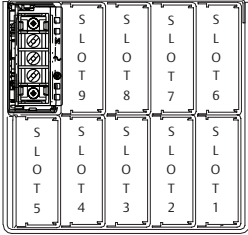

	Input	
	90-264 Vac	170-264 Vac
iVS1 = 5" x 5" x 11" (127 x 127 x 279.4) 9 available slots	1500 W max.	3210 W max.
iVS6 = 5" x 5" x 11" (127 x 127 x 279.4) 9 available slots 3-phase only	N/A	170-264 Vac 3210 W max.

iVS3, iVS8, and iVS8H

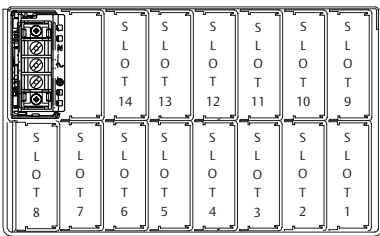

	Input	
	90-264 Vac	170-264 Vac
iVS3 = 5" x 8" x 11" (127 x 203.2 x 279.4) 14 available slots	1800 W max.	4500 W max.
iVS8 = 5" x 8" x 11" (127 x 203.2 x 279.4) 14 available slots	N/A	170-264 Vac 4920 W max.
iVS8H = 5" x 8" x 11" (127 x 203.2 x 279.4) 14 available slots	N/A	380 Vac 3800 W max. 480 Vac 4920 W max.

Pin Connectors

Figure 1. AC Input

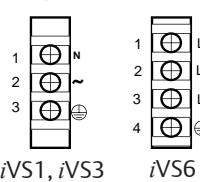

AC Input	Single Phase	3 Phase
Pin No.	Function	
1	AC neutral	Line 1
2	AC line (hot)	Line 2
3	Chassis (earth) ground	Line 3
4	Chassis (earth) ground	

Figure 2. Connector J1

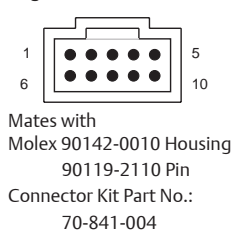

PFC Input Connector (control & signals)

Pin No.	Function
1	Input AC OK - "emitter"
2	Input AC OK - "collector"
3	Global DC OK - "emitter"
4	Global DC OK - "collector"
5	No connection
6	Global inhibit/optional enable logic "0"
7	Global inhibit/optional enable logic "1"
8	Global inhibit/optional enable return
9	+5 VSB housekeeping
10	+5 VSB housekeeping return

Figure 3. Connector J2

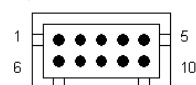

Mates with
Landwin 2050S1000 housing
2053T011P pin
Connector Kit Part No.:
70-841-023

I²C Bus Output Connector

Pin No.	Function
1	No connection
2	No connection
3	No connection
4	Serial clock signal (SCL)
5	Serial data signal (SDA)
6	Address bit 0 (A0)
7	Address bit 1 (A1)
8	Address bit 2 (A2)
9	Secondary return (GND)
10	5 VCC external bus (5 VCC bus)

iMP Modules

DC-DC Converter Output Modules

Control Signal Information, J1 Control Connector

Pin No.	Function	
1	+ Remote Sense	single or dual o/p main
2	Remote Margin / V. Program	single o/p
3	Margin High	single o/p
4	- Remote Sense / Margin Low	single or dual o/p main
5	Spare	
6	Module, Isolated Inhibit	single or dual o/p
7	Module Inhibit return	single or dual o/p
8	Current Share (SWP)	single or dual o/p main
9	+ Remote Sense V2	dual o/p, single is spare
10	- Remote Sense V2	dual o/p, single is spare

*Note: All iMP modules have a green DCOK LED.
(except for 36 W module)

Figure 4. Connector J1

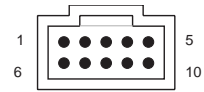

Mates with
Molex 90142-0010 Housing
90119-2110 Pin

Single 210 Watt

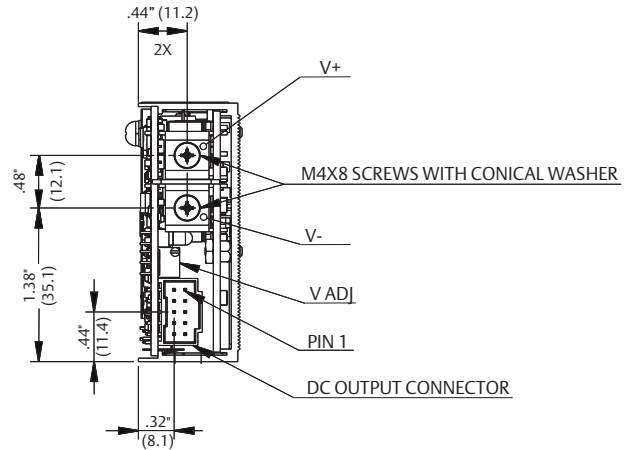

Single 360 Watt

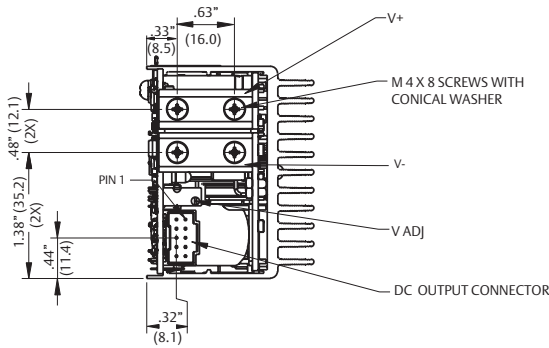

Single 750 Watt

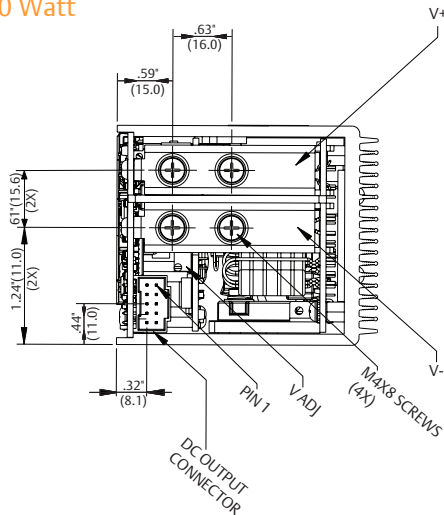

Single 1500 Watt

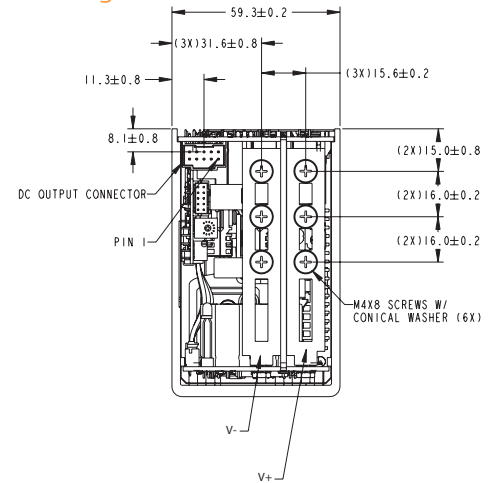

Dual 144 Watt

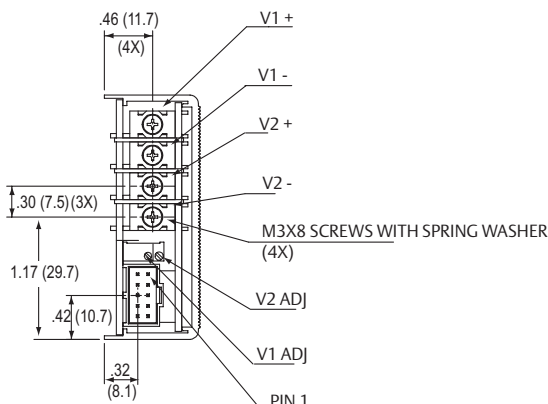

Triple 36 Watt

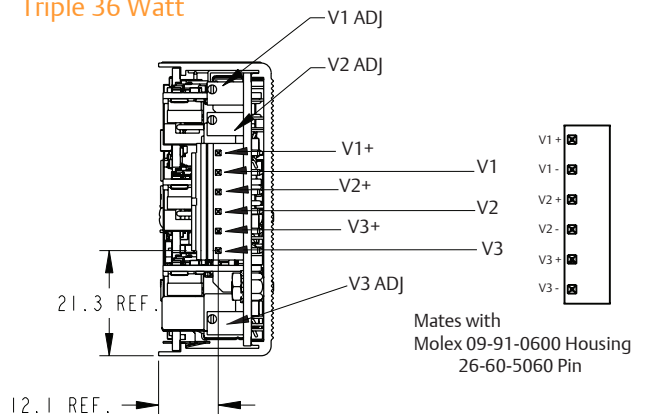

iVS Series

iVS1 (1500/3210 Watts Max)

5-Inch Case Size: iVS1: 5" x 5" x 11" (127mm x 127mm x 279.4mm)
 Weight: iVS1 Case: 6.2 lbs. • 1500 W Single: 2.0 lbs. • 750 W Single: 1.6 lbs.
 • 360 W Single: 1.0 lb. • 210 W Single: 0.6 lb. • 144 W Dual: 0.6 lb.

Rev. 12.2.09_41
 iVS Series
 7 of 11

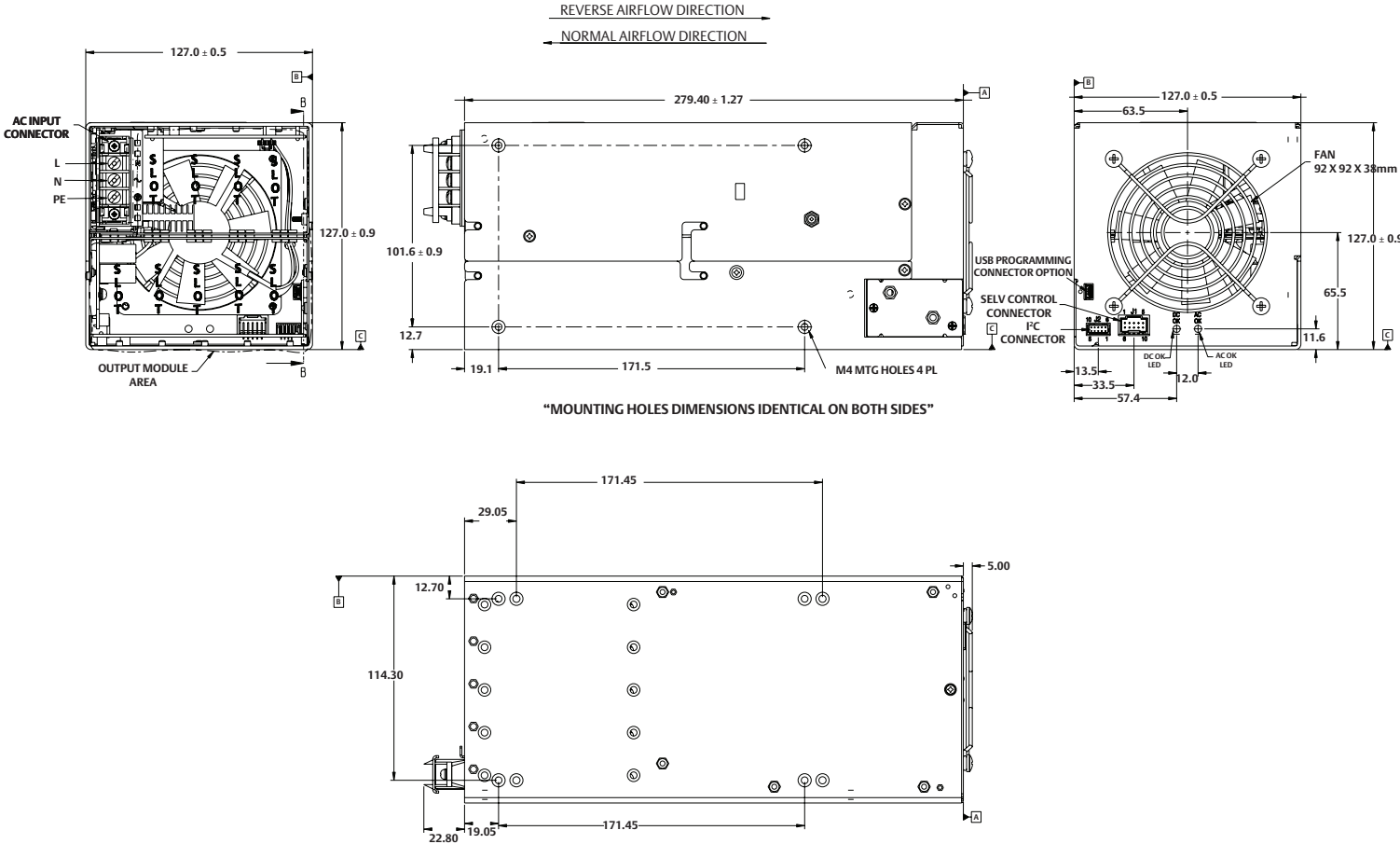

Notes

1. Input: Barrier type. Three No. 6-32 B.H. screws (0.375" centers). Max torque: 6 in-lbs. (0.67 N-m).
2. Control connectors: (J1) 10 position housing, gold plated contacts. Mates with Molex 90142-0010 housing with 90119-2110 crimp contacts (Molex C - Grid III Series). Connector kit includes mating connector and 10 pins, Astec part #70-841-004. (J2) 10 position housing (Landwin 2051P1000T). Mates with housing 2050S1000 (Landwin) with 2053T011P (Landwin) pins.
3. Chassis material: aluminum with chemical film coating (conductive).
4. All dimensions are in millimeters and inches, and are typical.
5. Customer mounting -3 sides M4, bottom also includes 8-32 mounting holes. Max. penetration is 0.155" (4.0 mm). Max. torque: 5 in-lbs. (0.57 N-m).
6. Output module connections: All single O/P modules are M4 x 8mm screws. Max. torque: 10 in-lbs. (1.13 N-m). Dual O/P module is M3 x 8mm screws. Max. torque: 5 in-lbs. (0.57 N-m).