

REV	ECO	DATE	DESCRIPTION	DB
A	3955	30-Oct-08	RELEASE TO PRODUCTION	DMD

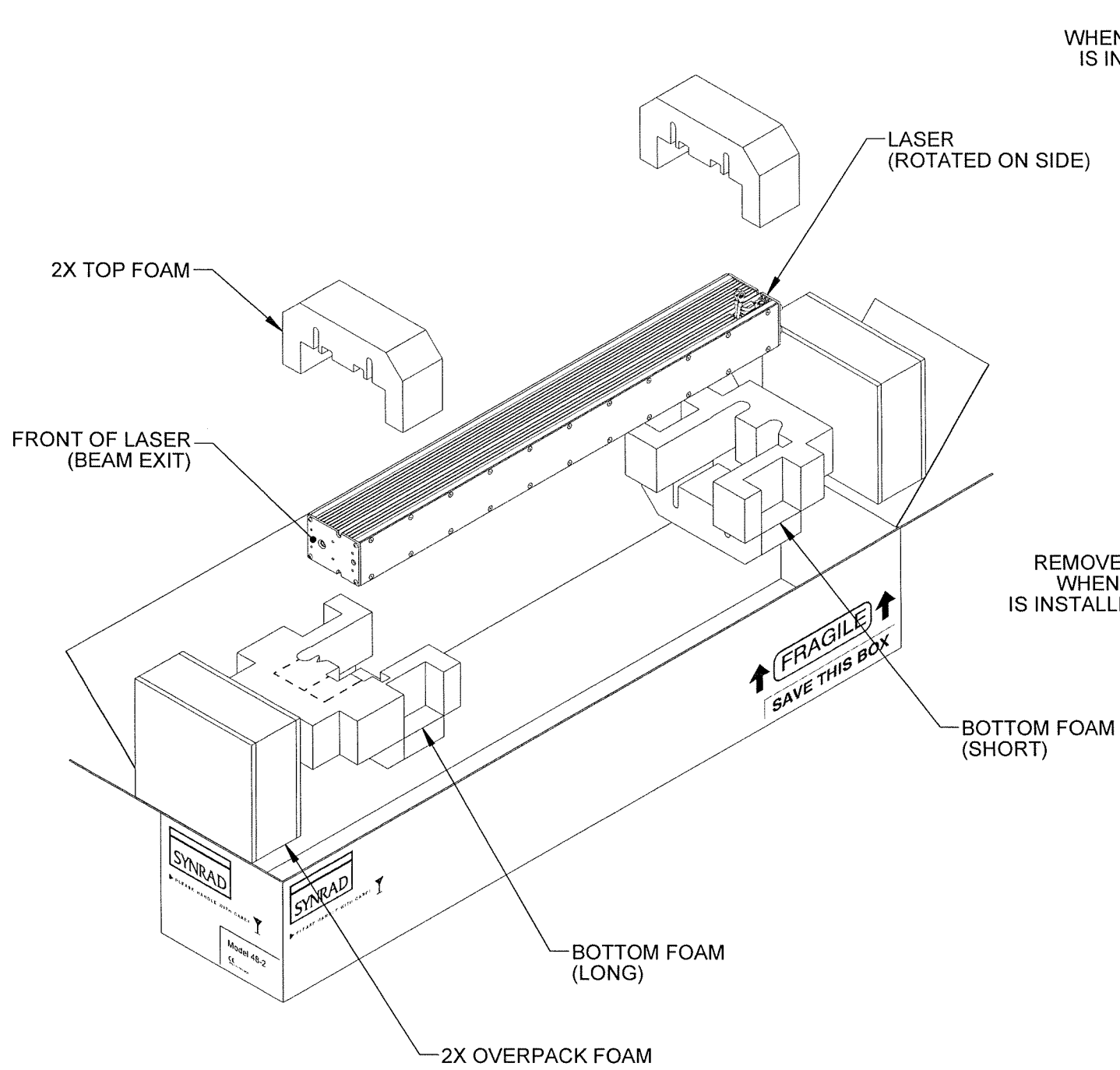

REMOVE SECTION 1
WHEN CLOSED LOOP DEVICE
IS INSTALLED (NOT SHOWN)

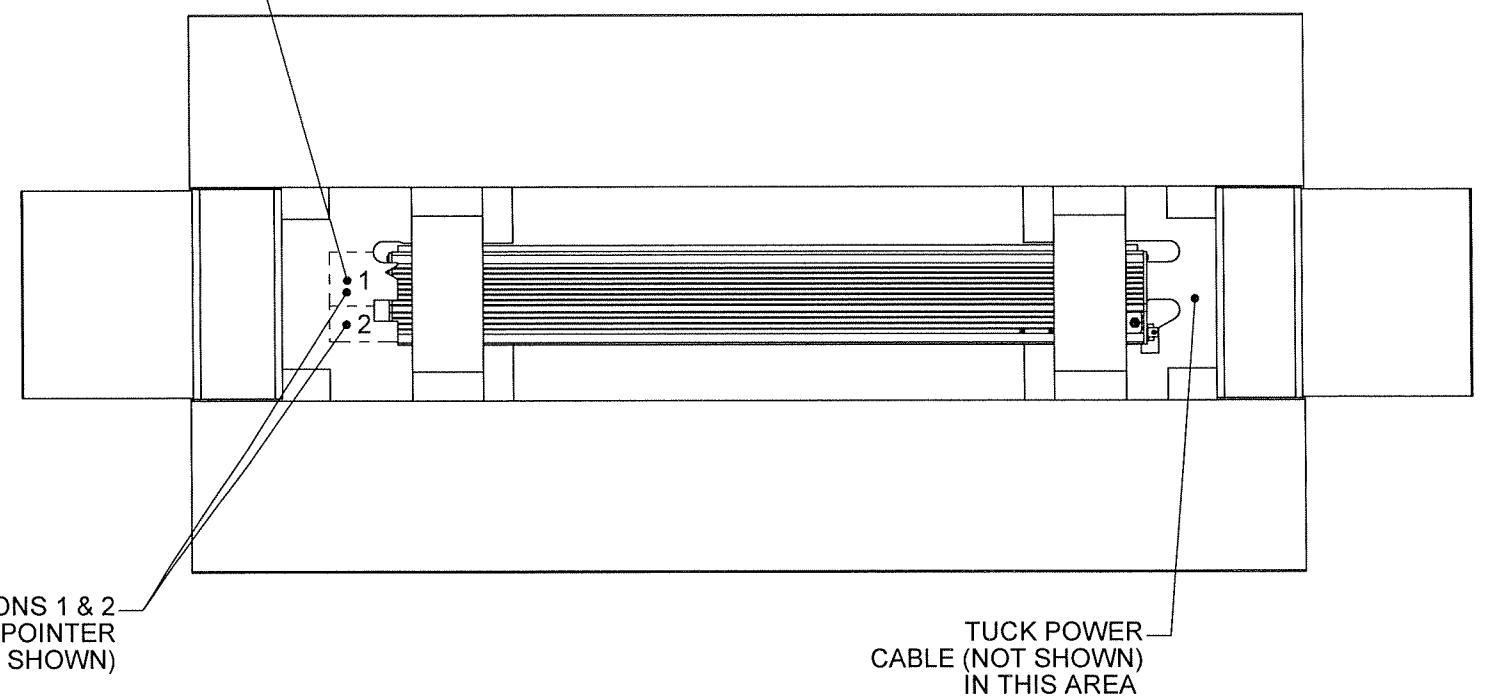

STEP-BY-STEP PACKAGING INSTRUCTIONS:

1. POSITION BOX SO LOGO ON TOP FLAP IS FACING YOU (LOGO WILL BE ON THE LEFT SIDE).
2. POSITION OVERPACK FOAM AND LONG AND SHORT BOTTOM FOAM INSIDE BOX AS SHOWN.
3. ROTATE LASER AND PLACE INSIDE FOAM CAVITIES AS SHOWN, MAKING SURE FRONT OF LASER IS ON THE LEFT SIDE AND BOTTOM OF LASER IS FACING YOU.
4. PULL CABLES TO RIGHT SIDE AND COIL. NOTE: CABLES NOT SHOWN FOR EASE OF ILLUSTRATION.
5. PLACE TOP FOAM OVER LASER AND SECURE INTO BOTTOM FOAM NOTCHES AS SHOWN.
6. TUCK CABLE AS SHOWN.
7. DO NOT SHIP WITH KEY IN SWITCH TO AVOID DAMAGE TO KEYSWITCH.
8. WRITE SYNRAD RETURN AUTHORIZATION NUMBER ON OUTSIDE OF SHIPPING BOX.

IMPORTANT NOTE: FAILURE TO PROPERLY PACKAGE LASER USING SYNRAD SHIPPING BOX AND FOAM/CARDBOARD INSERTS AS SHOWN MAY VOID WARRANTY. CUSTOMERS MAY INCUR ADDITIONAL REPAIR CHARGES DUE TO SHIPPING DAMAGE CAUSED BY IMPROPER PACKAGING.

TOLERANCES UNLESS NOTED:		PROPRIETARY THIS DRAWING IS PROPRIETARY TO SYNRAD INC. AND SHALL NOT BE USED OR DISCLOSED IN WHOLE OR IN PART WITHOUT WRITTEN PERMISSION OF SYNRAD INC.		 SYNRAD INC. 4600 Campus Place Mukilteo, WA 98275 Phone: (425)349-3500 Fax: (425)349-3667	
.x = ± 0.1	ANGLE = ± 0.5°				
.xx = ± 0.01					
.xxx = ± 0.005		DESCRIPTION: PACKAGING, 48-2			
MATERIAL: SEE BOM		PART NUMBER: 900-19845-01	DWG/FILE NUMBER: 900-19845-01		
FINISH:		SHEET 1 of 1	ENG: .	DRAWN BY: D. DUVAL	DATE: 25-Aug-08
		UNITS: Inches	CATEGORY: I	CHECKED BY: <i>T. Bleistner</i>	DATE: 10/30/08
		SIZE: B	FINISH CLASS: .	APPROVED BY: <i>WR</i>	DATE: 10/31/2008