

REV	ECO	DATE	DESCRIPTION	DB
A	3968	10-Nov-08	RELEASE TO PRODUCTION	DMD

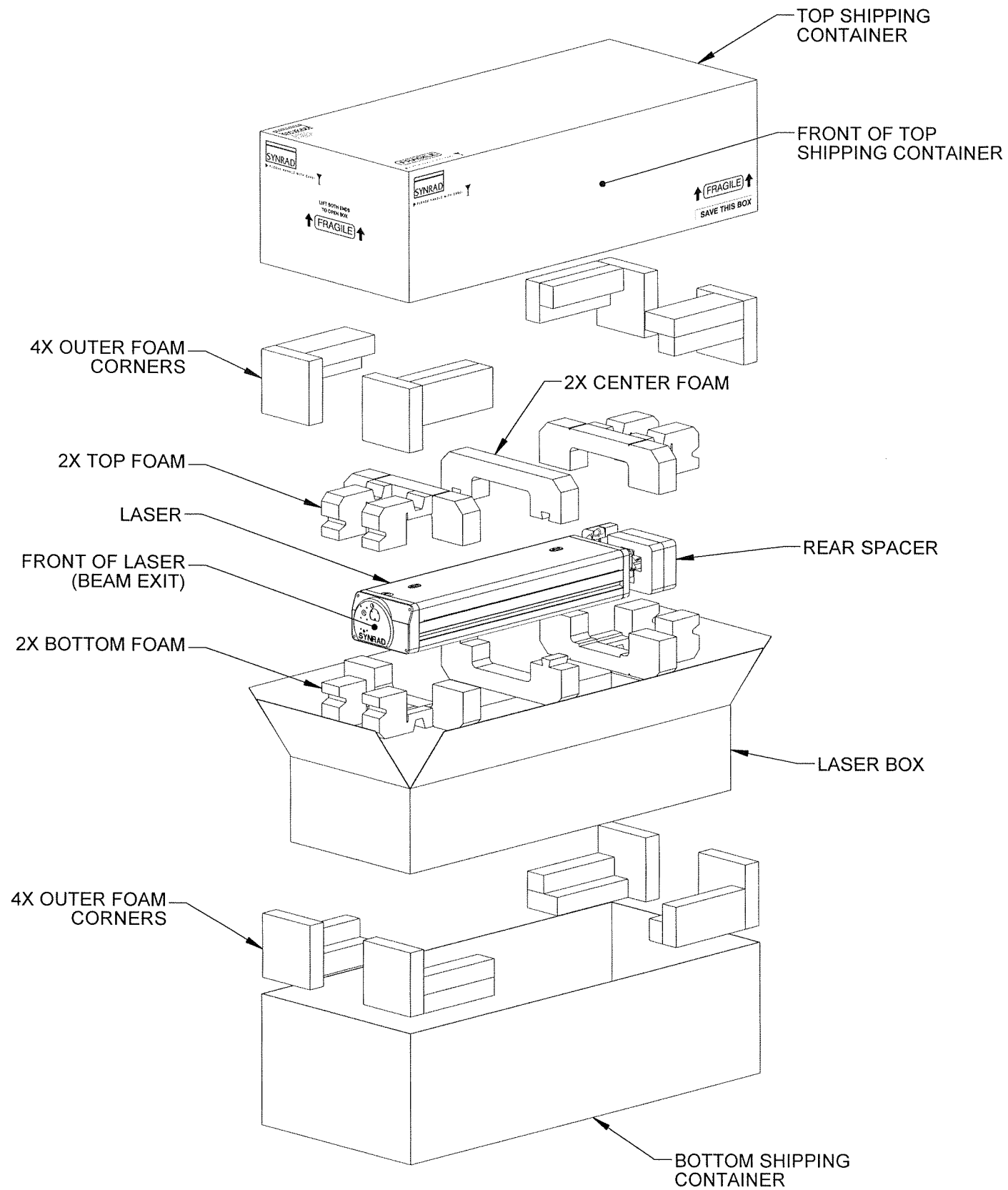

STEP BY STEP PACKAGING INSTRUCTIONS:

1. PLACE FOUR OUTER FOAM CORNERS INSIDE BOTTOM SHIPPING CONTAINER AS SHOWN.
2. PLACE BOX INSIDE SHIPPING CONTAINER ON TOP OF OUTER FOAM CORNERS AS SHOWN.
3. PLACE FRONT, CENTER, AND REAR BOTTOM FOAM INSIDE LASER BOX.
NOTE: CENTER PIECE SHOULD BE CENTERED IN THE BOX AS BEST AS POSSIBLE.
4. FIT REAR SPACER OVER FITTINGS AND PLACE LASER INSIDE FOAM CAVITIES AS SHOWN, MAKING SURE FRONT OF LASER IS ON THE LEFT SIDE.
5. PLACE FRONT, CENTER, AND REAR TOP FOAM OVER LASER AND SECURE.
6. CLOSE AND SEAL BOX AS REQUIRED.
7. PLACE FOUR OUTER FOAM CORNERS ON OUTSIDE CORNERS OF LASER BOX.
8. COVER WITH TOP SHIPPING CONTAINER AND SECURE AS REQUIRED.
9. DO NOT SHIP WITH KEY IN SWITCH TO AVOID DAMAGE TO KEYSWITCH.
10. WRITE SYNRAD RETURN AUTHORIZATION NUMBER ON OUTSIDE OF SHIPPING BOX.

TOLERANCES UNLESS NOTED:	
.x = ± 0.1	ANGLE = ± 0.5°
.xx = ± 0.01	
.xxx = ± 0.005	
MATERIAL: SEE BOM	
FINISH:	

PROPRIETARY
THIS DRAWING IS PROPRIETARY TO SYNRAD INC. AND SHALL NOT BE USED OR DISCLOSED IN WHOLE OR IN PART WITHOUT WRITTEN PERMISSION OF SYNRAD INC.

	SYNRAD INC. 4600 Campus Place Mukilteo, WA 98275 Phone: (425)349-3500 Fax: (425)349-3667		
	DESCRIPTION: PACKAGING, EVO 200/240		
PART NUMBER:	900-19885-01	DWG/FILE NUMBER:	900-19885-01
SHEET 1 of 1	ENG:	DRAWN BY: D. DUVALL	DATE: 10-Nov-08
UNITS: Inches	CATEGORY: I	CHECKED BY: <i>[Signature]</i>	DATE: 3/18/2009
SIZE: B	FINISH CLASS:	APPROVED BY: <i>[Signature]</i>	DATE: 3/18/09

IMPORTANT NOTE: FAILURE TO PROPERLY PACKAGE LASER USING SYNRAD SHIPPING BOX AND FOAM/CARDBOARD INSERTS AS SHOWN MAY VOID WARRANTY. CUSTOMERS MAY INCUR ADDITIONAL REPAIR CHARGES DUE TO SHIPPING DAMAGE CAUSED BY IMPROPER PACKAGING.