

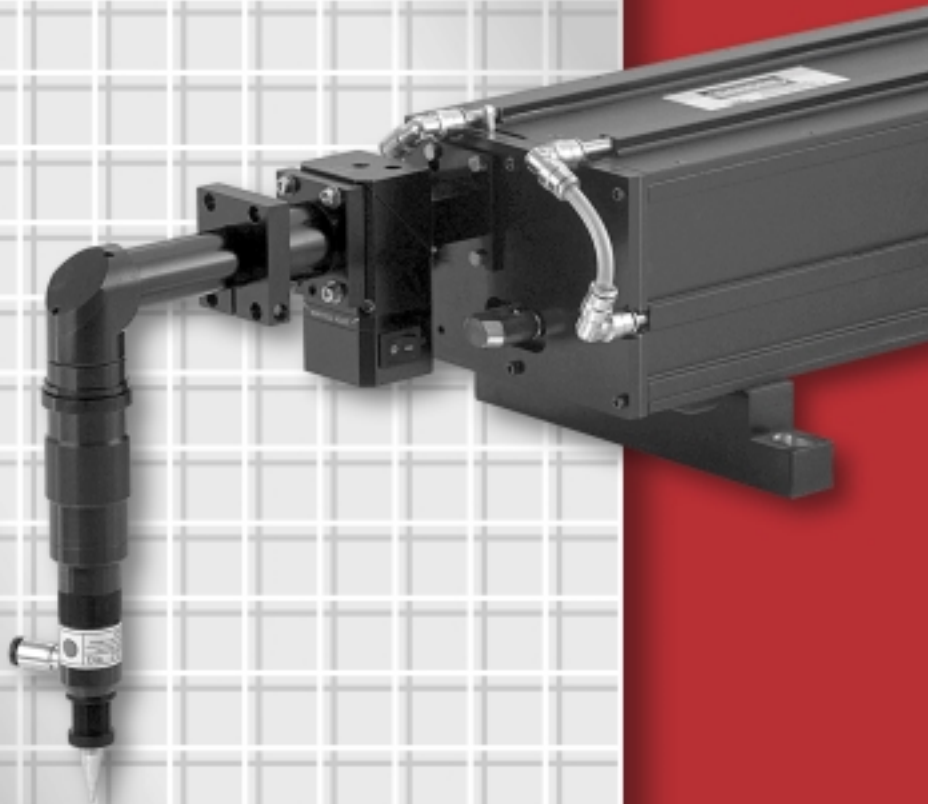

# 1.25" Series



**SOLUTIONS FOR**

**INDUSTRIAL**

**BEAM DELIVERY**



## 1.25 SERIES INDUSTRIAL ARTICULATED ARM

1.25 Series Industrial Articulated Arm (ATA) is a seven mirror arm consisting of 8 precision ball bearing rotary joints and 7 prealigned right angle mirror knuckles. The length of the arm is designed for reasonable access around the ends of robots or over x-y plotters.

- Tubes are hollow, made of anodized aluminum
- The clear aperture of the arm is available in 15mm or 19mm
- The natural beam divergence of popular small sealed lasers allows use of the 15mm arm in almost all cases if the arm is mounted close to the laser. The Synrad 200 Series requires the 19mm arm
- Arm launching accessories consisting of an adjustable beam bender and mount plate are also available

**Model PLATA0119** Articulated Arm

**Model PLAAM0001** Articulated Arm Mount

*Articulated Arm Mount*

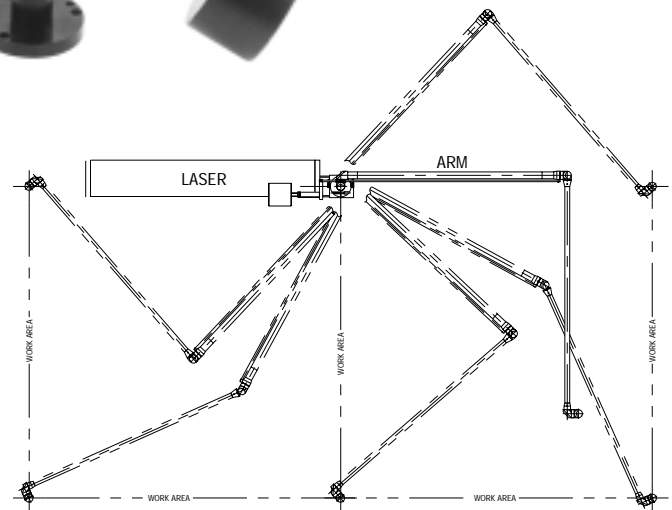

*Arm Used To Connect A Laser To A Flat Bed Cutter*

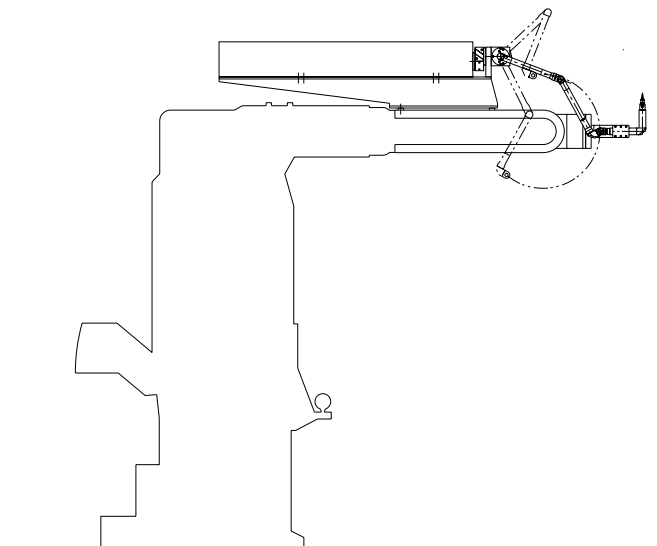

*Arm Used To Connect A Laser To A Robot Arm*

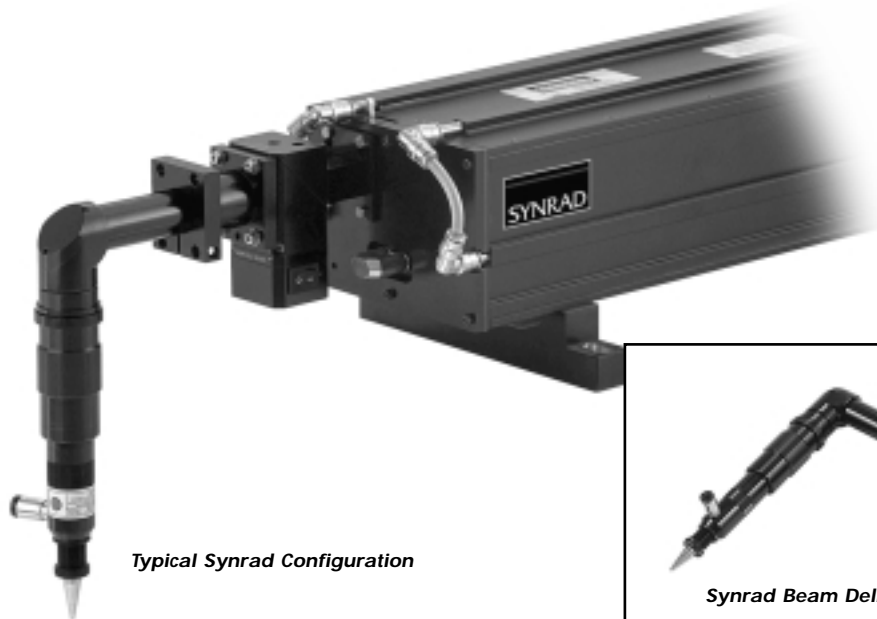

*Typical Synrad Configuration*



*Synrad Beam Delivery System*

## 1.25 SERIES COMPACT BEAM DELIVERY SYSTEMS

1.25 Series Compact Beam Delivery Systems offer a turnkey beam delivery solution for small output Synrad and Diamond sealed CO<sub>2</sub> lasers. Specifically designed for smaller lasers, compact systems offer a significant price advantage over traditional full-size components. Designed and manufactured to the same exacting standards as our full-size components, compact systems

deliver a level of performance, reliability and ease of installation that's unmatched in their class.

Let our team of laser system engineers analyze your compact beam delivery needs. We'll provide a design for a performance guaranteed beam delivery system for your laser machine or new industrial laser-based product.



*Typical Coherent Configuration*



*Coherent Beam Delivery Systems*



# 1.25" SERIES

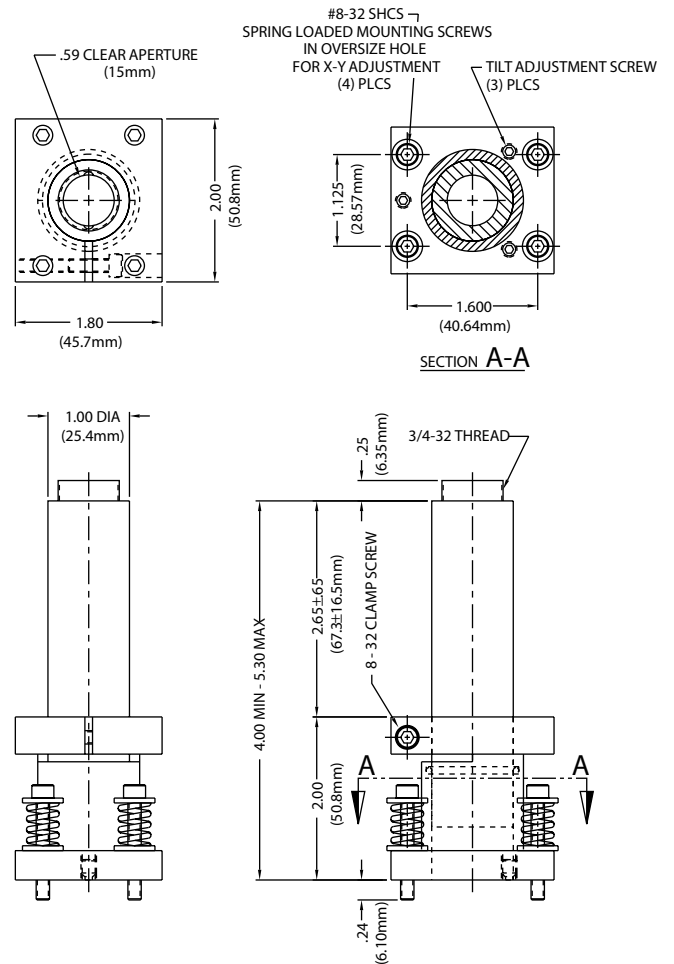

**Model PLLMS0008**

## 1.25 SERIES SYNRAD MOUNTING SYSTEMS

1.25 Series Synrad Mounting Systems are available in two different styles, the PLLMS0004 and PLLMS0008. Both models incorporate an adapter swivel clamp through which a path enclosure tube can be slipped and clamped. The path enclosure tube has 1.30" of travel within the clamp. The clamping feature allows the tube to slide back and forth and can be used as a coarse focus adjust or adjustable length mounting tube. The rectangular clamp mounts with 8 – 32 screws. An “O” ring inside the adapter clamp keeps the beam path sealed. The PLLMS0008 has added adjustable tilt and translation feature.

**Model PLLMS0004** Fixed Mounting System (Synrad Lasers)

**Model PLLMS0008** Adjustable Mounting System (Synrad Lasers)



**Model PLLMS0004**

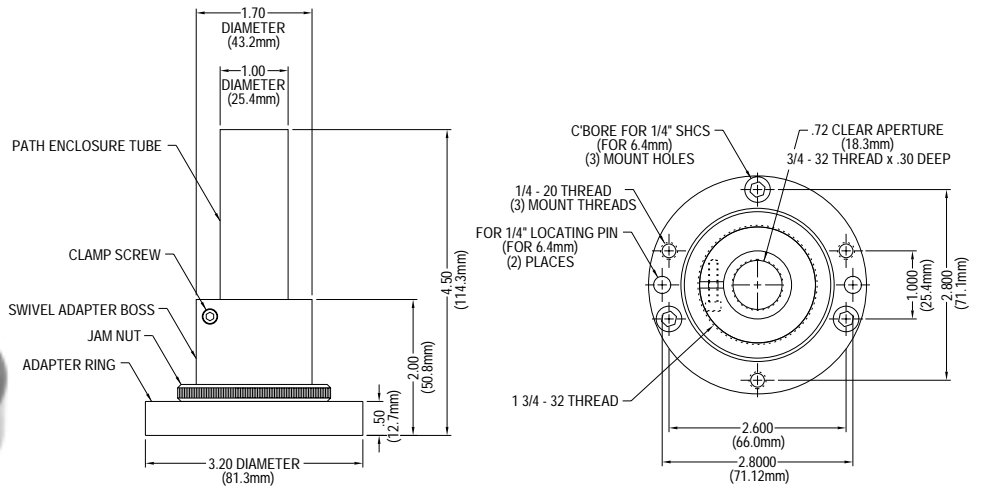

Model PLLMS0001

## 1.25 SERIES COHERENT MOUNTING SYSTEMS

1.25 Series Coherent Mounting Systems are available in two different styles.

The PLLMS0001 incorporates an adapter boss swivel clamp through which a path enclosure tube can be slipped and clamped. The outside has a 1.75 – 20 thread which will adapt to the flange of many standard lasers or to the adapter ring provided. A 1.75 – 20 jam nut allows the boss to be oriented in the desired direction in the ring or flange. The clamping feature allows the path enclosure tube to slide back and forth (2" travel) and can be used as a coarse focus adjust or adjustable length mounting tube. An "O" ring inside the adapter boss keeps the beam path sealed.

The second style, the PLADP0021, is specifically designed for Mini-Diamond lasers and allows the mounting of beam benders at 45 and 90 degree angles.

**Model PLLMS0001** Mounting System (Coherent Diamond Lasers)

**Model PLADP0021** Mounting System (Coherent Mini-Diamond Lasers)



Model PLADP0021  
(For Mini-Diamond Series)

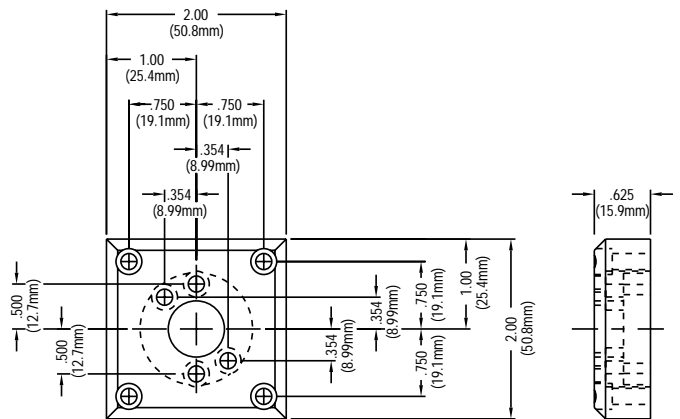

# 1.25" SERIES



## 1.25 SERIES BEAM BENDERS

1.25 Series Beam Benders (BBA) are fully adjustable, highly stable 90 degree Beam Benders with a clear aperture of 15mm.

- The adjustment system consists of a fixed plane pivot and two 80 pitch tilt screws. Access to these screws is through two small holes in the body of the bender block.
- A 1.5mm hex wrench can be used to make fine adjustments in the mirror angle of  $\pm 2$  degrees
- The face referenced 1.0" diameter, 3mm thick mirror can be removed and replaced with an accuracy of better than .00001 radian
- The mirror is contained in a cap which can be easily removed for cleaning
- Both the input and output faces have a .75 – 32 female thread for mounting the bender or attaching it to other 1.25 Series components
- A male threaded connector is also included
- The PLBBA0074 has the added benefit of two 8 – 32 tapped holes for screw mounting to adapter plates such as the PLADP0021

**Model PLBBA0041** Beam Bender

**Model PLBBA0074** Beam Bender Screw Mount

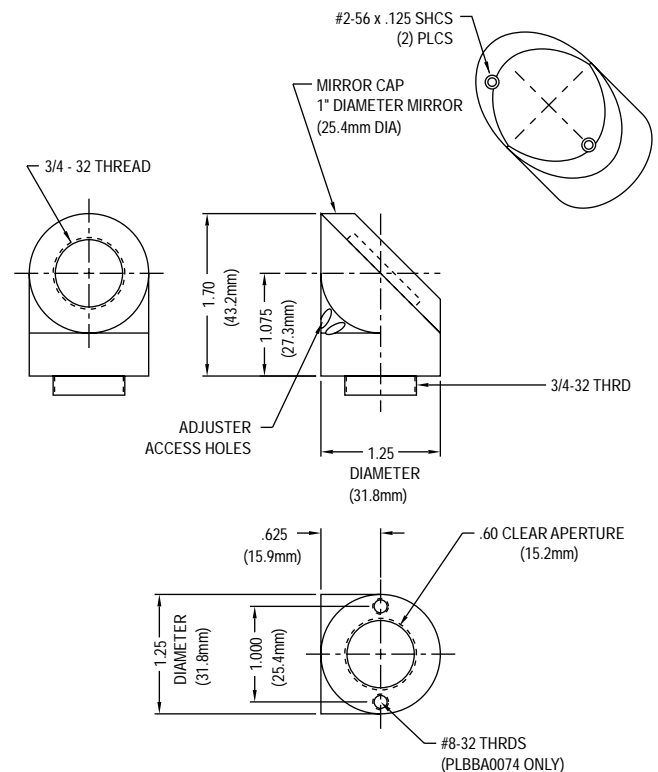

**Models PLBBA0041/PLBBA0074**



PLDPA0003



PLDPA0009

### 1.25 SERIES DIODE POINTER ASSEMBLIES

1.25 Series Diode Pointers (DPA) contain a ZnSe beam combiner which transmits the CO<sub>2</sub> beam and reflects a red laser diode. The diode can be centered to adjust the near field coincidence and the combiner angle is adjustable for far field coincidence of the diode beam to the CO<sub>2</sub> beam. This eliminates the need for cumbersome IR viewing instruments.

Diode Pointers also provide the important safety benefit of enabling the laser user to clearly monitor the loca-

tion of the CO<sub>2</sub> beam without being exposed to the high-power beam. Diode Pointers can be mounted to many of today's popular sealed CO<sub>2</sub> lasers.

A variety of diode pointers are available with different mounting configurations. Contact a Laser Mech laser system engineer for available models.

**Model PLDPA0003** Diode Pointer (Synrad Lasers)

**Model PLDPA0009** Diode Pointer With Power Monitor Port (Coherent Mini-Diamond Lasers)

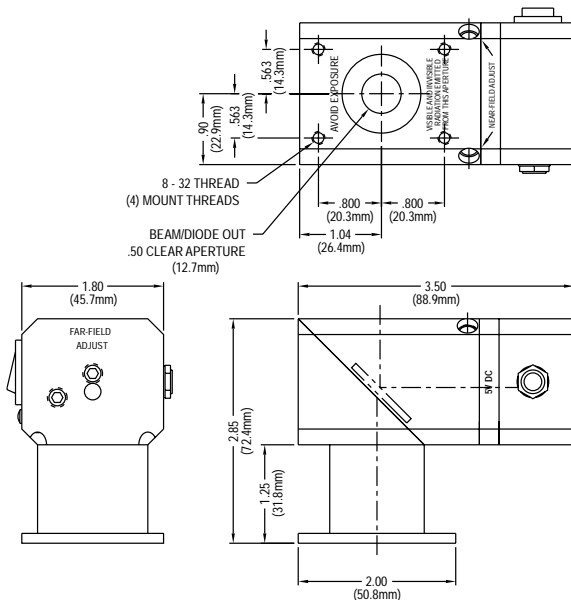

Model PLDPA0003

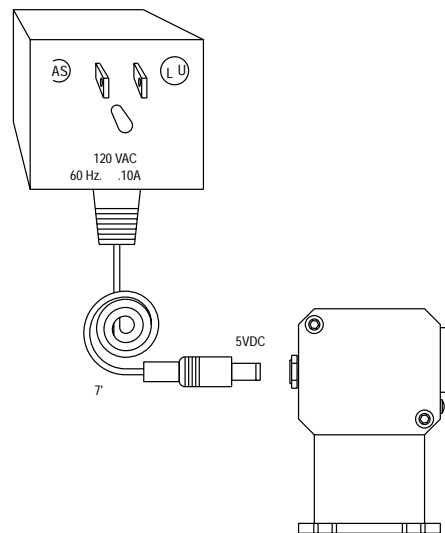

# 1.25" SERIES



## 1.25 SERIES VERNIER ADJUST SPACER

1.25 Series Vernier Adjust Spacer (VAS) provides a fine focus adjustment for the lens mounted in the gas jet manifold. Turning the knurled ring advances or retracts the non rotating focus tube .05" per turn. A scale on the focus tube provides a reference of exact axial position. All threads and sliding joints are sealed to prevent dirt from entering the mechanism or beam path.

- The unit is of black anodized aluminum construction
- The full travel of the slide tube is 1.5"
- A lock nut holds the spacer in position
- Each end of the VAS has a .75 – 32 female thread
- A male threaded adapter for attaching it to other 1.25 Series components is included

**Model PLVAS0022** Vernier Adjust Spacer 1.25" Series

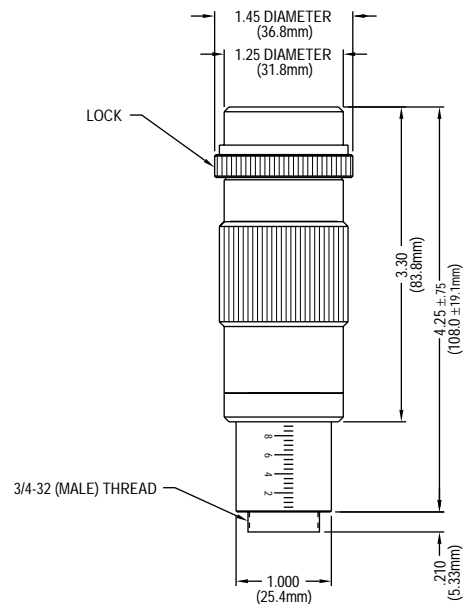
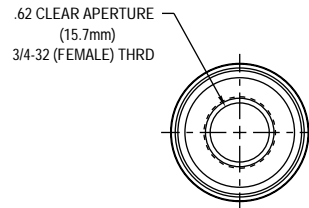

**Model PLVAS0022**



## 1.25 SERIES GAS JET MANIFOLDS

1.25 Series Gas Jet Manifolds (GJM) include:

- A lens holder housing with a .75" diameter lens of the focal length selected premounted in the housing body
- An input adapter with a female .75 – 32 thread to mate to other 1.25 Series components
- A gas inlet fitting for .25" OD tubing to admit gas below the lens
- An adjustable length extension tube with jam nut and tip retainer nut set for the length of lens selected
- A removable gas jet tip



The Gas Jet Tip (GJT) standard orifice is .063", the material is copper and the tip is tapered to .10" diameter. For optimum cutting, blunt-shaped tips and other orifice diameters and materials are available. They can be ordered separately.

**Model PLGJM0102** Gas Jet Manifold 1.5" Focal Length

**Model PLGJM0105** Gas Jet Manifold 2.5" Focal Length

**Model PLGJM0107** Gas Jet Manifold 4.0" Focal Length

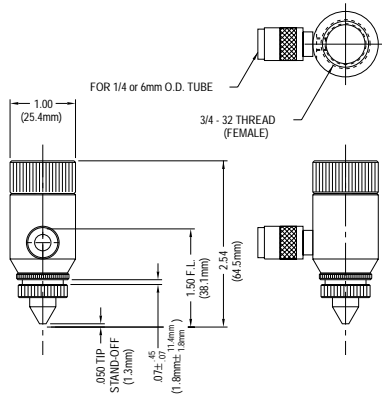

Model PLGJM0102

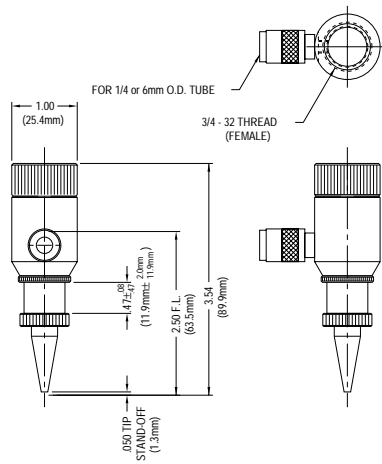

Model PLGJM0105

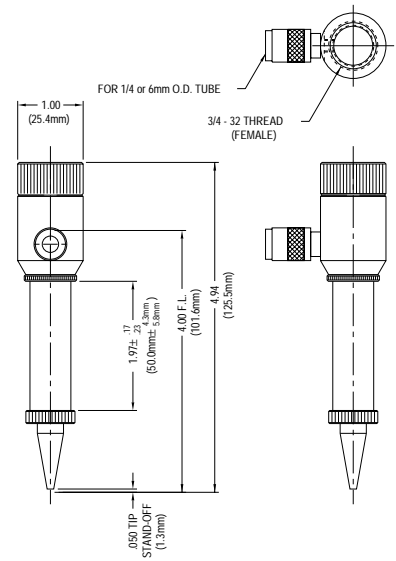

Model PLGJM0107

The longer the lens, the more standoff distance is available. Consult individual manifold drawings for exact details on this parameter.

For applications where a gas jet is not required, the tip can simply be removed or a simple lens holder is available to replace the entire gas jet manifold.

# 1.25" SERIES



## 1.25 SERIES PATH ENCLOSURE TUBES

1.25 Series Path Enclosure Tubes (PET) are anodized aluminum tubes which can be used to support other 1.25 Series components and enclose the beam path. The inside diameter is 18mm and each end has a female .75 – 32 thread with a male threaded connector in one end. This allows several tubes to be connected in series or attached to other components.

The 1" outside diameter tubes are machined so they

can be clamped in mounting swivel bosses which are part of the system.

The tubes shown are only an example of the variety of PETs available. Consult a Laser Mech laser system engineer for a PET that's right for your system.

**Model PLPET0134** Path Enclosure Tube 4"

**Model PLPET0130** Path Enclosure Tube 10"

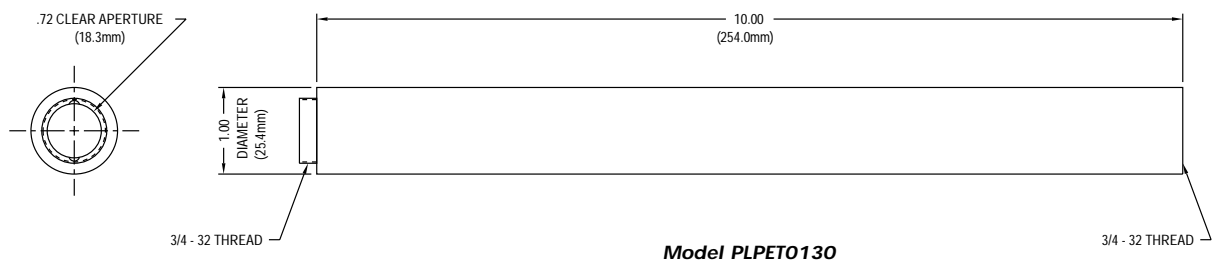
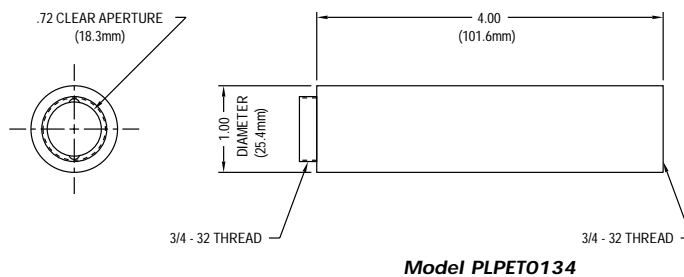



### 1.25 SERIES ADAPTER CLAMP

1.25 Series Adapter Clamp (ADC) accepts path enclosure tubes which can then be slipped and clamped. The clamping feature allows the tube to slide back and forth and rotate to allow length and angle adjustments between components – such as two beam benders. This allows beam benders to be rotated to any angle desired.

**Model PLADC0001** Adapter Clamp 1.25" Series

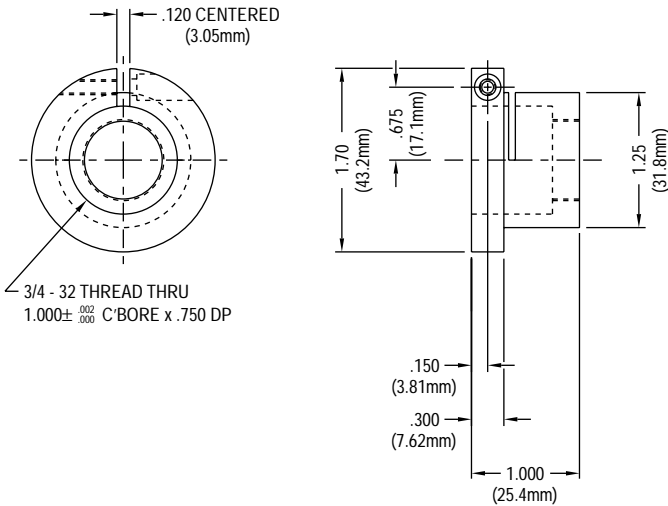

**Model PLADC0001**



### 1.25 SERIES COLLIMATORS

1.25 Series Collimators (COL) are used to expand the beam 1.6X, 2.0X or 2.5X, with an output aperture of 15mm, consistent with the rest of the series. Collimators are used selectively when the delivery system is very close to the laser and the "F" number of the system must be lowered to achieve the smallest spot size possible.

When ordering, make sure the intended exiting beam (input beam dia. x collimator ratio) will be no larger than 14mm, so it can safely clear the 15mm exit aperture.

**Model PLCOL0052** 1.6X Collimator

**Model PLCOL0053** 2.0X Collimator

**Model PLCOL0054** 2.5X Collimator

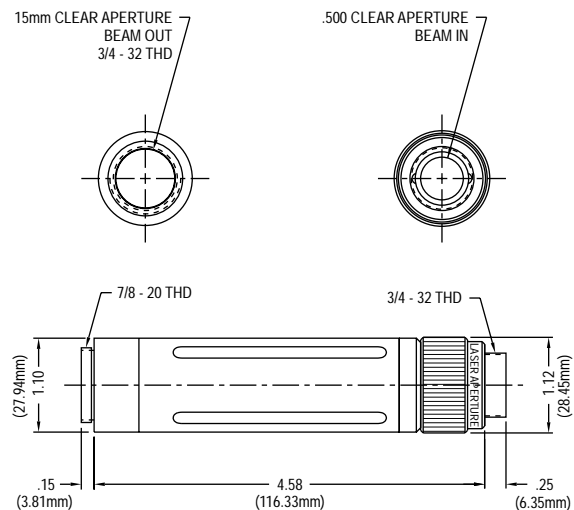

**Model PLCOL0052**

# 1.25" SERIES



## 1.25 SERIES BEAM COMBINER BLOCK & OVER THE LENS VIEWER

1.25 Series Beam Combiner Block (BCB) allows the addition of a side viewing port for attachment of a TV camera viewing system or a diode laser coaxial pointing beam. The unit consists of a splitter block and cap for a 1.0" diameter ZnSe beam combiner. The block provides for the proper offset due to the refraction of the laser beam combiner optic. The input port has a .75 – 32 female thread and the exit port has a .795 – 32 female thread with an adapter to .75 – 32 male thread. The viewing port has a .625 – 32 female thread with male adapter included.

1.25 Series Over The Lens Viewer (OLV) is a lens system which can be used with a 2.5" to 5.0" focal length ZnSe lens. It can also be used with any "C" mount CCD camera and monitor for viewing through the laser focusing lens at the work piece. It mounts to the viewing port of the BCB with a .625 – 32 male adapter.

**Model PLBCB0001** Beam Combiner Block

**Model PLOLV0024** Over The Lens Viewer

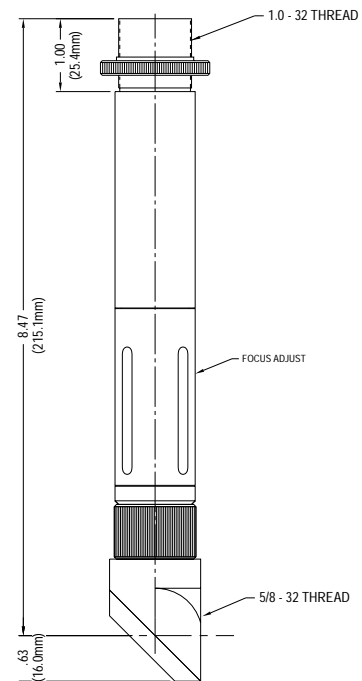
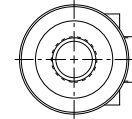
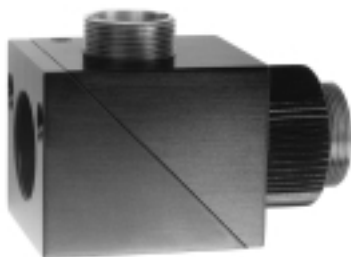

**Model PLOLV0024**

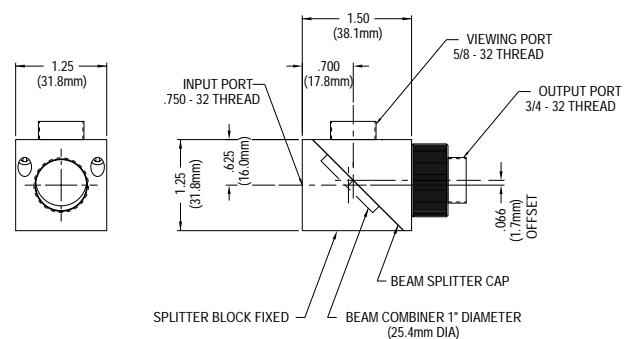

**Model PLBCB0001**

## 1.25 SERIES CUT QUALITY ENHANCERS

1.25 Series Cut Quality Enhancers (CQE) are used with linearly polarized lasers to produce a circularly polarized beam. When the laser is used for multidirectional cutting processes, a uniform kerf will be obtained. The CQE unit mounts directly to the face of Diamond lasers and provides a surface to remount their standard adapter plate.

The laser mount plate of the unit has three 10 – 32 brass-tipped set screws which provide the reference plane against the front of the laser and are used to adjust the angle of the exiting beam to its original direction. The mirrors contained in the CQE are one 90 degree reflective phase retarder and one zero phase

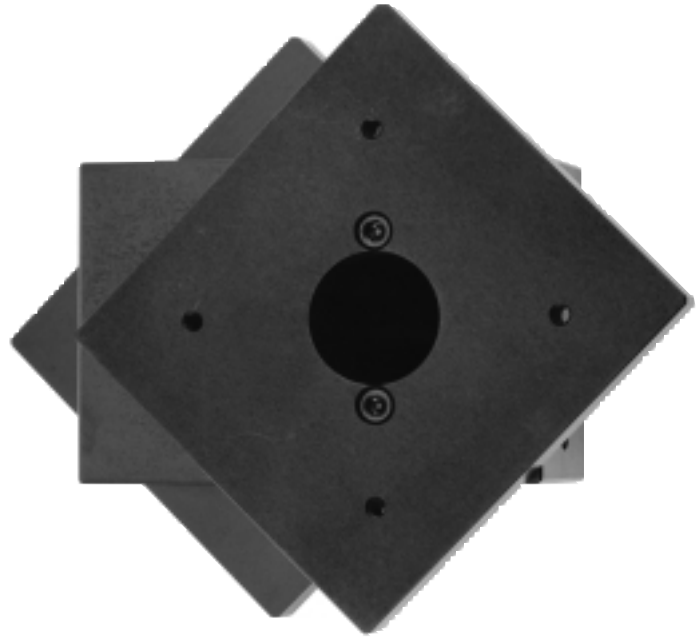

shift mirror. Both are 1.5" diameter, 4mm thick silicon substrate mirrors.

**Model PLCQE0048** 25mm Cut Quality Enhancer

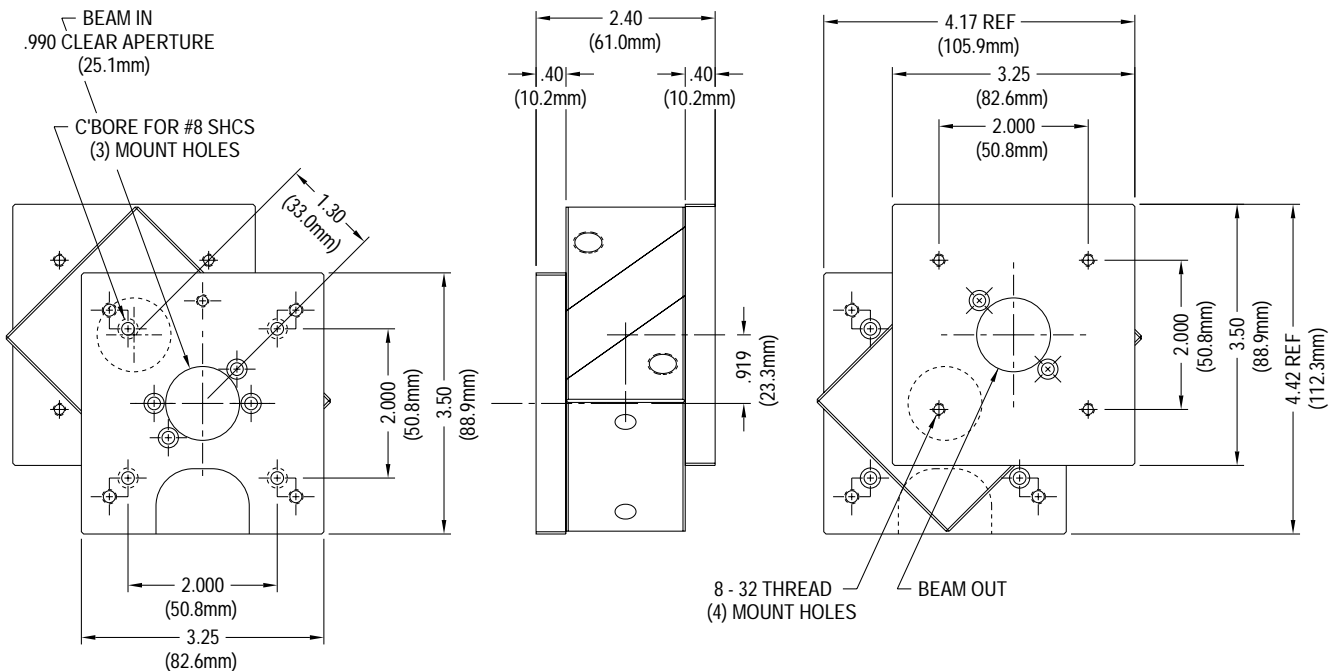

**Model PLCQE0048**

# 1.25" SERIES

## 1.25 SERIES FEEDBACK ISOLATOR

1.25 Series Feedback Isolator (FBI) rejects back reflections off the workpiece, which can upset the laser's intra-cavity conditions, destroying mode quality and power stability. Many process quality problems are traced to this phenomenon.

The Feedback Isolator is designed to work with Diamond lasers and it is composed of one feedback isolator optic, two zero-phase shift mirrors and one-phase shifting optic. The Feedback Isolator acts as a polarization analyzer and is located directly in front of the laser output aperture. The S-polarized laser beam from the laser is 98.5 percent reflected by the FBI optic. The beam then enters the second stage of the FBI where it becomes circularly polarized and exits the assembly. Reflections perpendicular to the workpiece will re-enter the circular polarizer where once again they become linearly polarized, except this time the polarization vector is rotated 90 degrees making the



beam P-polarized. The Feedback Isolator absorbs the P-polarized beam thereby preventing it from re-entering the laser cavity.

Water cooling fittings are provided for use with lasers above 200 watts. The aperture of this device even allows it to be used with larger diameter lasers such as the Coherent K-500.

**Model PLFBI0006** Feedback Isolator 1.25" Series

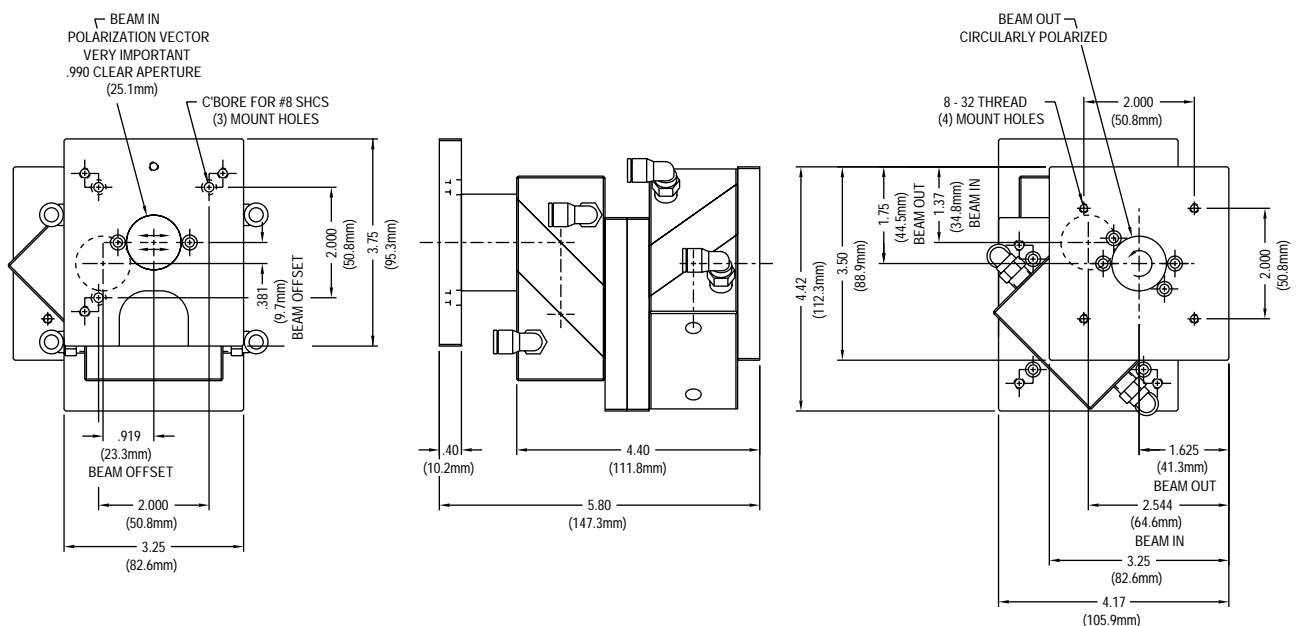

**Model PLFBI0006**

**1.25 SERIES  
TARGETS & ACCESSORIES**

1.25 Series Alignment Tool Kit contains the following:

- Beam Bender Target (BBT) has a clear aperture of 9mm and crossed 1mm wires. It inserts into the .625 aperture of the male threaded connector, used to couple the beam bender to the other components. Removing the mirror cap from the bender allows access to the beam from either direction
- Manifold Alignment Target (MAT) has an external .75 – 32 thread for connecting it into any aperture, such as the end of a VAS or PET, and an internal .625 – 32 thread for attaching in place of the gas jet tip retainer nut. The target has crossed 1mm diameter wires and a clear aperture of 15mm
- Wrenches consist of a 1.5mm hex wrench for mirror angle adjusting and a 3/4 hex wrench for removing the mirror cap
- Thermal Paper Cards are used to detect the low power CO<sub>2</sub> beam via a change in color from buff to black

1.25 Series Arm Adapter is used for mounting components to articulated arms.

**Model PLBBT0008** Beam Bender Target

**Model PLMAT0008** Manifold Alignment Target

**Model PLADB0004** Arm Adapter

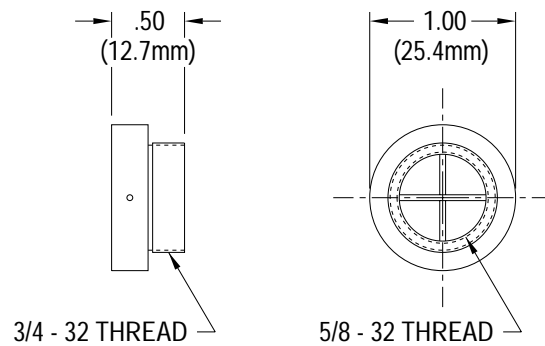

**Model PLMAT0008**

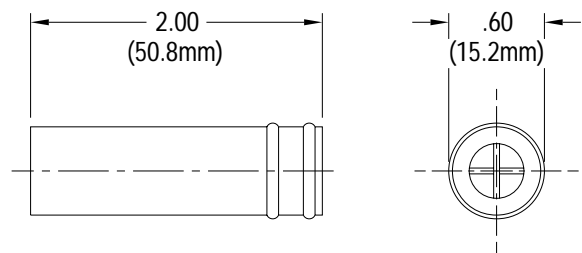

**Model PLBBT0008**

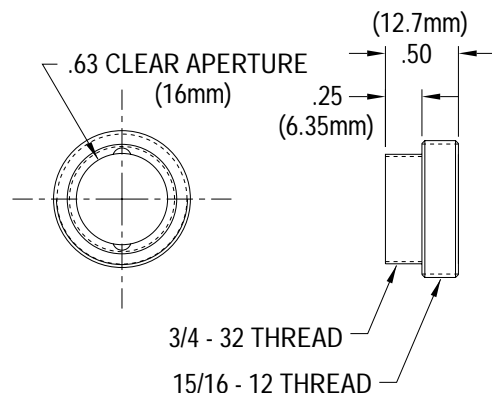

**Model PLADB0004**



Laser Mechanisms, Inc. specializes in Laser Beam Delivery Components to make the most of your laser.

**ALL WAVE LENGTHS • BEAM DIAMETERS TO SIX INCHES • CW POWER TO 25KW**

Let our staff of laser system engineers, with a total of over 200 years collective experience, supplement your in-house people. We will provide a design for a performance guaranteed beam delivery system for your special laser machine or new industrial laser based product. We are price effective and qualified to handle everything from the most basic to very sophisticated active sensing beam delivery systems.

— DISTRIBUTED BY: —



24730 Crestview Court • Farmington Hills, MI 48335 USA • Phone: (248) 474-9480 • Fax: (248) 474-9277  
In Europe: Phone: +32(0)92 18 70 70 • Fax: +32(0)92 18 70 79  
Web: [www.lasermech.com](http://www.lasermech.com) • E-Mail: [info@lasermech.com](mailto:info@lasermech.com)