

| REV | ECO | DATE | DESCRIPTION | DB |
|-----|------|-----------|--------------------------------------|-----|
| E | 3912 | 12-Aug-08 | ADD BEAM EXIT, CONVERT TO SOLIDWORKS | DMD |
| F | 4107 | 8-Sep-09 | ADD NOTE 5 | DMD |

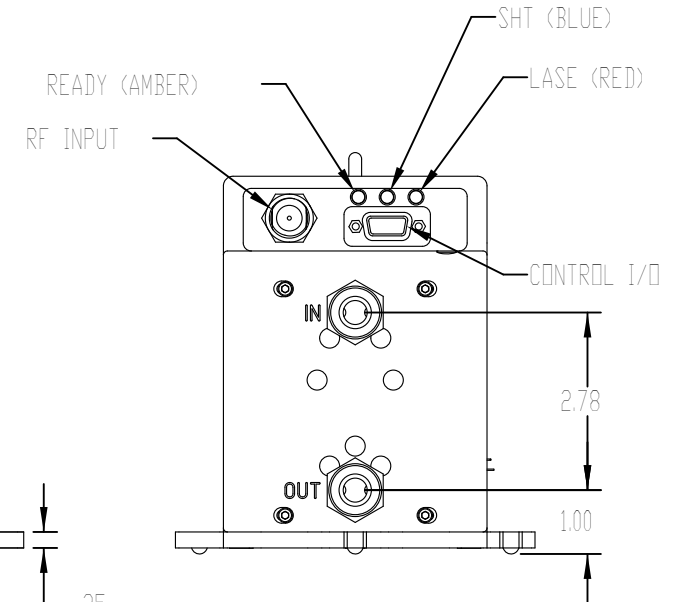

| PART NUMBER | MODEL |
|-------------|-------|
| FST60KW | KEY |
| FST60SW | DEM |
| FST80KW | KEY |
| FST80SW | DEM |
| FST100KW | KEY |
| FST100SW | DEM |

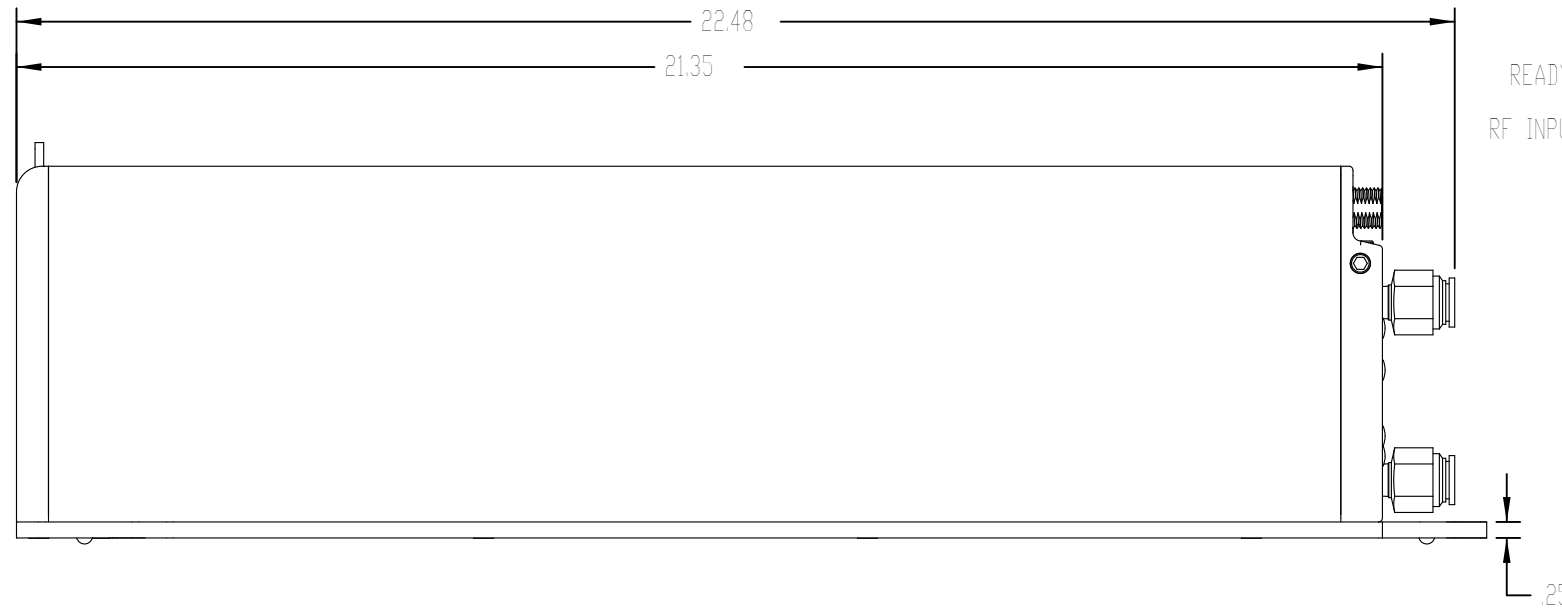
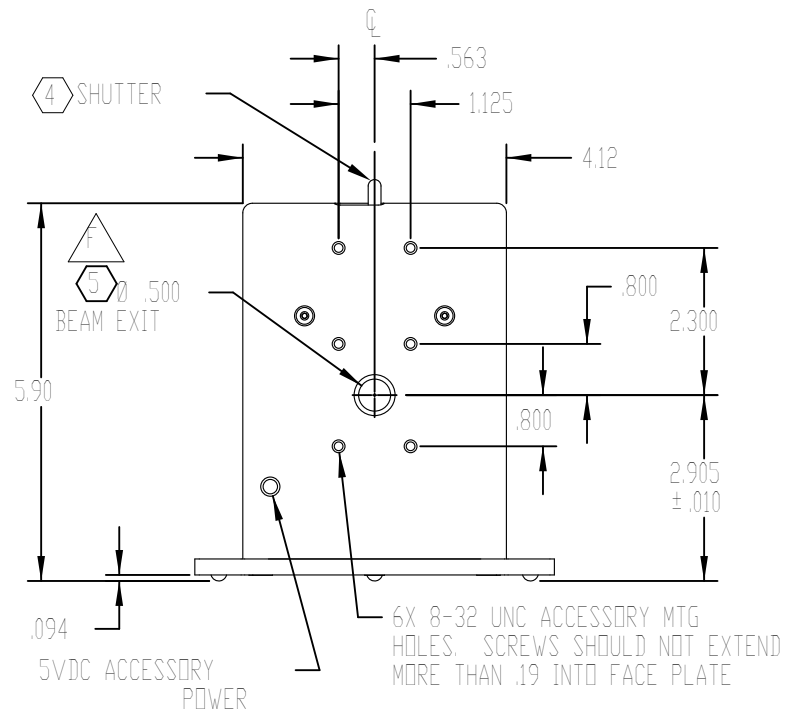
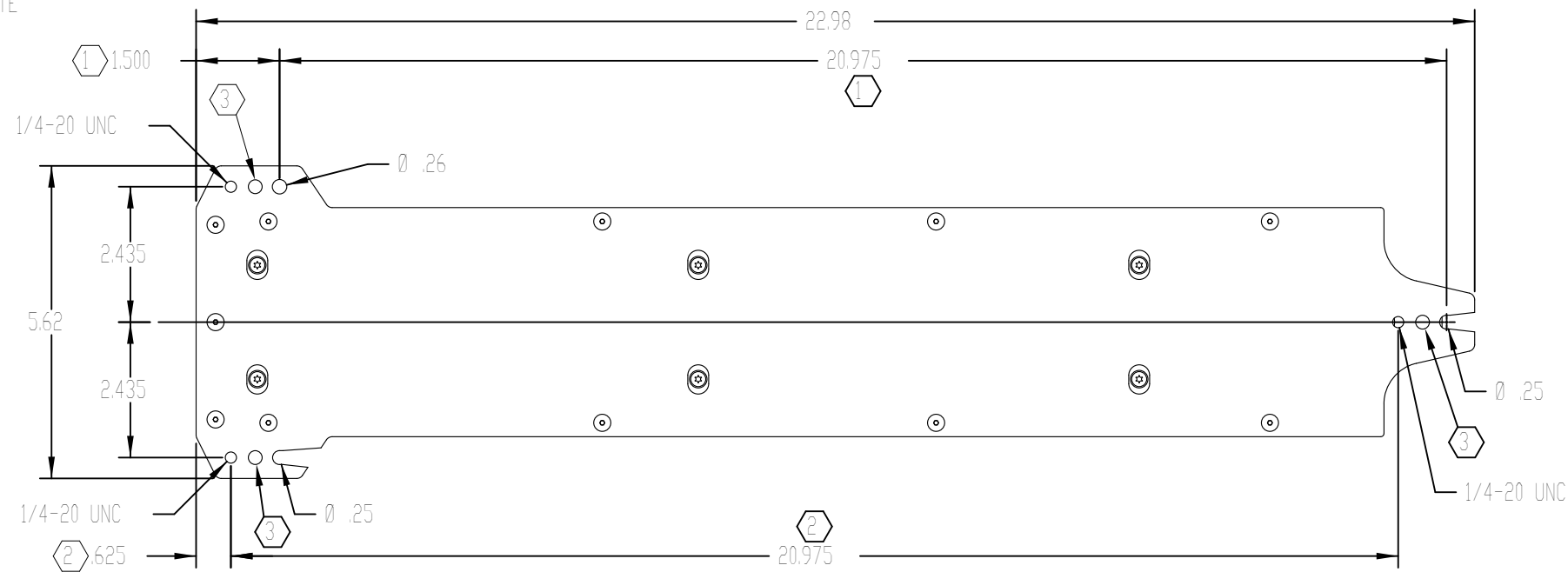

- NOTES:
- 1 THIS MOUNTING HOLE PATTERN USED WHEN TOP ACCESS FASTENING DESIRED.
 - 2 THIS MOUNTING PATTERN USED WHEN BOTTOM ACCESS FASTENING DESIRED.
 - 3 HARDENED BALL MOUNTING POINT, 3X. (Ø.250 BALL BEARING)
 - 4 KEYSWITCH VERSION ONLY.
 - 5 BEAM PATH MAY NOT BE CENTERED OR PERPENDICULAR TO FACEPLATE APERTURE.

| | |
|--------------------------|-----------------|
| TOLERANCES UNLESS NOTED: | |
| .x = ± 0.1 | ANGLE = ± 2.0 ° |
| .xx = ± 0.03 | |
| .xxx = ± 0.005 | |
| MATERIAL: | |
| FINISH: | |

PROPRIETARY
THIS DRAWING IS PROPRIETARY TO
SYNRAD INC. AND SHALL NOT BE
USED OR DISCLOSED IN WHOLE
OR IN PART WITHOUT WRITTEN
PERMISSION OF SYNRAD INC.

DESCRIPTION:
OUTLINE & MOUNTING, WATER-COOLED T60/T80/T100

| | | |
|---------------|--|-------------------------------|
| | SYNRAD INC. 4600 Campus Place Mukilteo, WA 98275 Phone: (425)349-3500 Fax: (425)349-3667 | |
| | PART NUMBER: SEE TABLE | DWG/FILE NUMBER: 300-18479-03 |
| SHEET 1 of 1 | ENG: | DRAWN BY: C.B. MILLER |
| UNITS: Inches | CATEGORY: | CHECKED BY: |
| SIZE: B | FINISH CLASS: | APPROVED BY: |
| | | DATE: 29-Nov-00 |
| | | DATE: |
| | | DATE: |