

WinMark Pro Application Note

WinMark Pro's Banner Tracking Functionality

FH Flyer marking heads and Fenix Flyer Laser Markers running firmware version 2.70 or higher and working with WinMark Pro version 6.0 or higher, support a new feature called Banner Tracking. The banner tracking function allows FH Flyer marking heads and Fenix Flyer Laser Markers to create marks on moving objects (tracking) where the mark extends beyond the extents of WinMark Pro's *Drawing Canvas*. This function is useful for marking long text strings, logos, or other objects, on lengths of cable, piping, tubing, etc. as the material moves through the mark field. Banner tracking text strings can be serialized as required by the application.

This Application Note does not cover standard tracking functionality in its entirety; this document provides only new information related to banner tracking or existing tracking properties that behave differently in banner tracking mode. For complete tracking details, see the Tracking chapter in your marking head's Operator's Manual or the *WinMark Pro Laser Marking Software User Guide*.

Banner tracking definitions

The definition of the terminology used in banner tracking is identical to standard tracking with the addition of one new term, the *Banner Window*. See the Tracking chapter in your marking head's Operator's Manual or the *WinMark Pro Laser Marking Software User Guide* to review standard tracking definitions.

Banner Window

The *Banner Window* is the area within the *Marking Window* (the area contained within the *Drawing Canvas*) where each segment of the banner mark is marked. Ideally, the *Banner Window* size, defined by the Banner Window Interval property, should cover no more than 50% to 75% of the length of the focusing lens's maximum mark field. WinMark Pro then breaks up the entire banner mark into multiple *Banner Windows* and marks each segment as it tracks through the *Tracking Window* (the area where marking is completed without error).

Banner tracking mark criteria

- In WinMark control mode (where WinMark sends microvector data to the head through a Ethernet or USB connection), the mark can consist of any vector objects, WinMark stroke text, TrueType®/ OpenType® style text, and bitmaps including 1D or 2D barcodes and black & white or grayscale bitmap graphics.
- In Stand-alone control mode (where the .mkh mark file resides in the head's Filestore or on a network share), the mark can consist of any vector objects, WinMark stroke text, TrueType-style text, and bitmaps including 1D or 2D barcodes and black & white or grayscale bitmap graphics.
- In Stand-alone control mode, the mark cannot contain OpenType-style text objects.
- Mark orientation—WinMark Pro marks text left to right, top to bottom, just as it is typed into the *Text Caption Editor* dialog. Text objects should be rotated as required so that the first character to be marked is the first character into, and out of, the *Marking Window*.

- Although WinMark Pro automatically adjusts marking to begin on the downstream edge of raster objects such as bitmap graphics, filled text, or barcodes in order to optimize banner tracking speed, the Raster Scan Direction property must be set so the scan direction is at right angles to the banner tracking direction.
- When marking raster-style objects, such as barcodes, try to position these objects so they do not cross a *Banner Window* boundary. This will eliminate any gaps, overlaps, or “stair steps” in situations where banner tracking parameters are not precisely adjusted.
- The Drawing’s field transformation properties (Field Offset X, Field Offset Y, Field Rotation, Field Transform Org X, and Field Transform Org Y) must be set to zero (0), their default values.
- When banner tracking, the Encoderless Tracking property should be set to *No* in order to prevent stitching mismatches at *Banner Window* boundaries. **We highly recommend the use of a position encoder** to account for the very slight variations seen in all part motion systems. Encoderless banner tracking will not provide acceptable results when subtle changes in part velocity occur.

Banner tracking hardware

The hardware required for banner tracking is identical to standard tracking hardware. See the Tracking chapter in your marking head’s Operator’s Manual or the *WinMark Pro Laser Marking Software User Guide* for detailed information.

WinMark Pro banner tracking setup

In WinMark Pro v6, the “*Device*” tab (labeled *Flyer70014* in Figure 1) contains head specific tracking setup parameters. These tracking properties are located on the “*Device*” tab because tracking parameters will vary slightly from head-to-head on production lines due to slight variations in encoder couplings, conveyor speeds, part sensor location, etc.

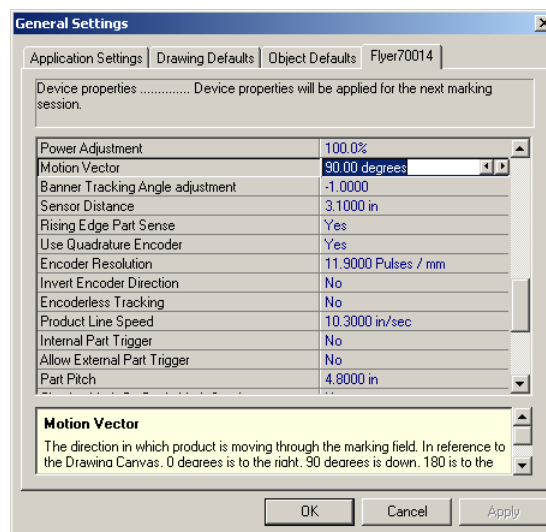

Figure 1 Tracking properties on “Flyer device” tab

To setup your Flyer/Fenix Flyer head for banner tracking, make sure that the head is communicating with WinMark Pro v6 (Ethernet or USB) and then edit the parameters described below. The properties described below are only those that affect banner tracking differently than standard tracking. For complete descriptions of all tracking properties, see the Tracking chapter in your marking head's Operator's Manual or the *WinMark Pro Laser Marking Software User Guide*.

Motion Vector

Set the direction of part movement through the mark field. When looking at WinMark Pro's *Drawing Canvas* (shown in Figure 2), 0° is part movement towards the right, 90° is movement towards the bottom, 180° is towards the left, and 270° is part movement towards the top of the *Drawing Canvas*.

When the Track Marking Object property is Yes, a motion arrow displays to the left of the *Drawing Canvas* showing the direction of the currently entered Motion Vector.

Note: Currently, banner tracking is supported only for Motion Vectors of 0°, 90°, 180°, and 270°. Part motions of either 90° or 270° provide the fastest line speeds because part movement is through the long axis of the mark field.

Note: The Drawing's Field Rotation property must be set to zero (0).

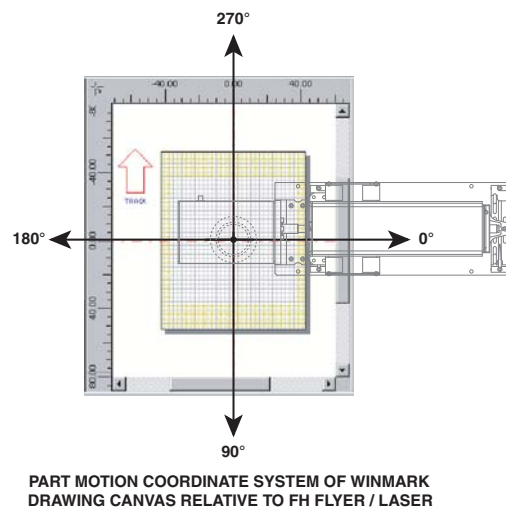

Figure 2 Drawing Canvas coordinates relative to marking head orientation

Banner Tracking Angle Adjustment

Use the Banner Tracking Angle Adjustment property to fine-tune any angular misalignment of the marking head to part movement. This property can only provide $\pm 0.15^\circ$ of adjustment; any further adjustment must be made by physically moving the marking head.

To fine-tune the banner tracking angle once the initial tracking setup is complete, create a mark file containing three parallel lines in the direction of travel as shown in Figure 3. Center one line on the *Drawing Canvas* and place the other two lines on each edge of the canvas.

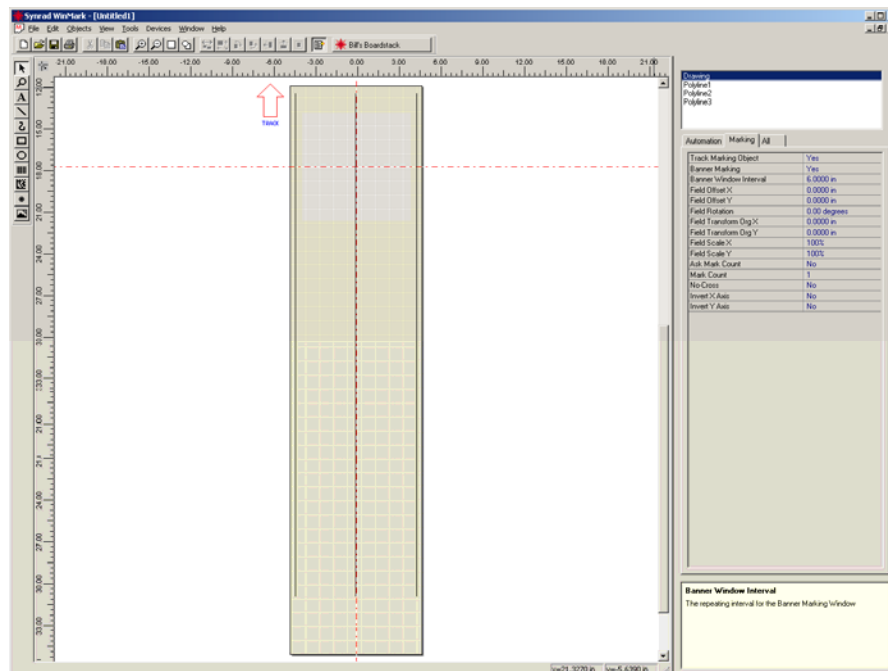

Figure 3 Mark file for fine-tuning Banner Tracking Angle Adjustment

While marking these lines, verify that each line is stitched together lengthwise without any offset. If one or more lines exhibit an offset or “stair step”, change the Banner Tracking Angle Adjustment property value until all three lines are straight, without any offsets or steps.

Note: Gaps, overlaps, or steps in any of the three lines indicate that either Encoder Resolution and/or Banner Tracking Angle Adjustment values must be adjusted as described in the *Banner tracking optimization* section.

Sensor Distance

The term Sensor Distance is not entirely accurate because the value entered is not related to the physical part sensor location, but rather Sensor Distance is defined as **the distance, at the moment of part sense, from the centerline of the Marking Window to the leading edge of the desired mark location on the part.**

Change Sensor Distance to move the location of the mark on the part in the axis of part motion. Moving the location of the mark object on WinMark's *Drawing Canvas* (in the axis of part motion) has no effect on part mark location although, when banner tracking, the leading edge of the mark should be positioned halfway between the top of the *Drawing Canvas* and the center (0,0 coordinates) as shown in Figure 4. This location establishes the top edge of the first *Banner Window*.

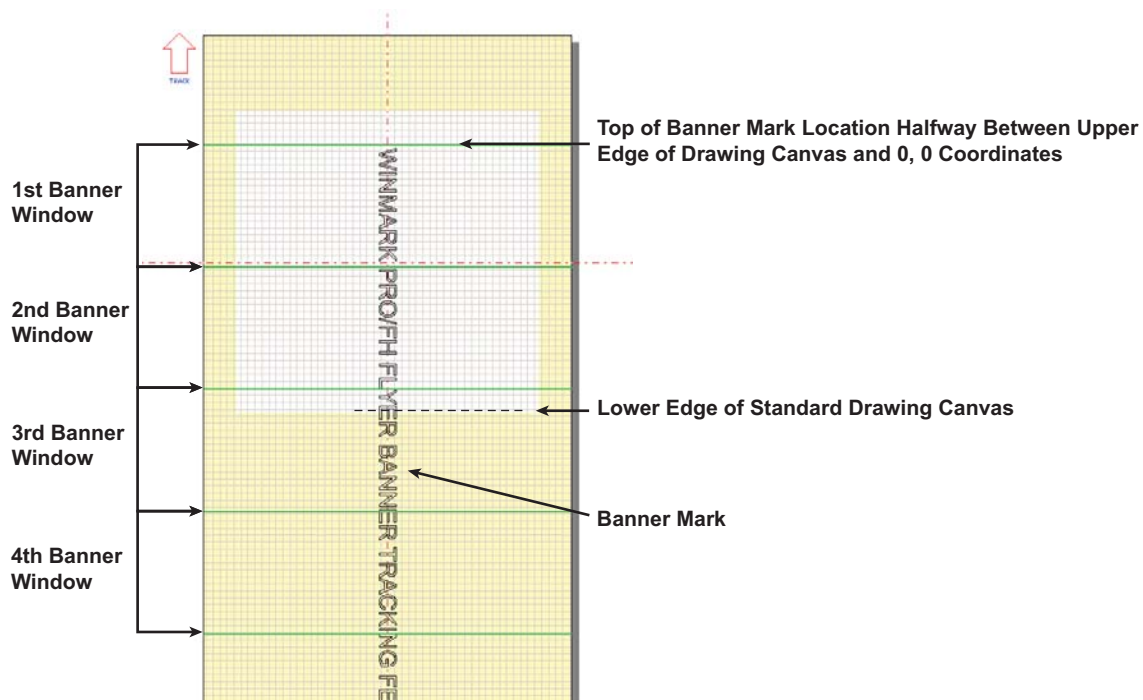

Figure 4 Banner mark location on Drawing Canvas

Encoder Resolution

Encoder Resolution is the number of encoder pulses received per millimeter of distance traveled by the part conveyor. This property value is accurate to four decimal places (0.0001 pulses per millimeter). To obtain accurate banner tracking, it may be necessary to fine-tune this property to the third or fourth decimal point.

Before fine-tuning the Banner Tracking Angle Adjustment property, first adjust Encoder Resolution to eliminate any gaps or overlaps in the lines in the setup file (the three parallel lines shown in Figure 3) as described in the *Banner tracking optimization* section.

Encoderless Tracking

We highly recommend that you set Encoderless Tracking to *No* and install a position encoder. A position encoder connected directly to the motion system provides the best accuracy when mark objects extend across *Banner Window* boundaries. Encoderless banner tracking will not provide acceptable results when subtle changes in part velocity occur.

Part Pitch

When using internal triggering (Internal Part Trigger property is *Yes*), an error will occur if the Part Pitch property is set to a value smaller than the total length of all combined banner intervals required to mark the entire object. In applications where parts are spaced very close together, you must carefully select a Banner Window Interval value that is close to a multiple of the mark's total length. For example, a part is banner marked with a 200 mm length of text. If you enter a Banner Window Interval value of 150 mm, the mark would be made in two banner window intervals for a total length of 300 mm.

Therefore, the closest spacing for the next part would be 100 mm due to the extra space left over in the second banner interval (two banner windows with a total length of 300 mm minus the 200 mm text mark). In this case, the minimum Part Pitch is 300 mm. If you picked a Banner Window Interval of 100 mm, the total length of the two combined banner intervals would be 200 mm, matching the length of the actual mark, and you would have the closest spacing possible; where the parts can be positioned end-to-end (using a Part Pitch property value of 200 mm).

Mark file banner tracking setup

Set the following properties to configure a Flyer/Fenix Flyer head for banner tracking. When the *Drawing* object is selected, these three banner tracking properties appear on the *Marking* tab:

Track Marking Object

As with a standard tracking mark, set Track Marking Object to *Yes*.

Banner Marking

When Track Marking Object is *Yes*, the Banner Marking property appears. To perform a banner mark, set this property to *Yes*.

Banner Window Interval

When Banner Marking is *Yes*, the Banner Window Interval property appears. The Banner Window Interval determines the size of the banner marking area, the *Banner Window*. The numeric value entered should be no more than 50% to 75% of the length of the focusing lens's maximum mark field (the *Marking Window*). Ideally, this value is the distance extending approximately halfway between the top of the *Drawing Canvas* and the center (0, 0 coordinates).

If the Banner Window Interval is too large (greater than 75% of the length of the *Marking Window*), "line speed too fast to finish" errors may occur. If the Banner Window Interval is too small, the computer (in WinMark control mode) or the Flyer head (in Stand-alone mode) must perform more mathematical calculations, resulting in sub-optimal line speeds.

Refer back to the Part Pitch description for information on how the Banner Window Interval affects Part Pitch and minimum part spacing.

Note: In WinMark builds 7492 and above, Banner Window Intervals are displayed as solid green lines spaced horizontally across the *Drawing Canvas*.

Determining line speed

Because banner tracking marks typically extend beyond the *Marking Window*, it is not possible to calculate line speed as done in standard tracking. Banner tracking line speeds must be determined experimentally.

Banner tracking optimization

Optimize the banner tracking setup

- 1 First, run the appropriate *linestackxxx.mkh* file and adjust Encoder Resolution (as described in your marking head's Operator's Manual) until all long and short lines in the linestack file appear as a single long line.
- 2 Create a banner tracking setup file as shown back in Figure 3.
- 3 Run the banner tracking setup file and fine-tune the Encoder Resolution value as required to eliminate line gaps or line overlaps as shown by lines "A" through "D" in Figure 5. When gaps or overlaps are eliminated, proceed to Step 4.

Note: Although your mark may exhibit "stair steps" because of angular misalignment, there should be no gaps or overlaps between the steps.

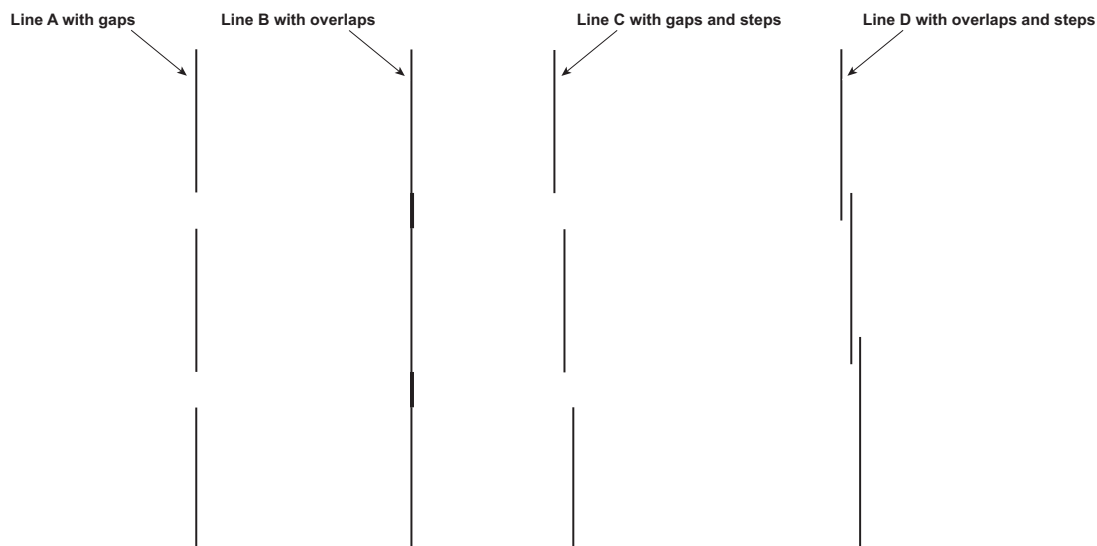

Figure 5 Illustration of lines showing gaps and overlaps between Banner Windows

- 4 If the mark produced by the banner tracking setup file has “stair steps” as shown by line “E” in Figure 6, fine-tune the Banner Tracking Angle Adjustment value, increasing or decreasing the angle in the range of -0.15° to $+0.15^\circ$. If you cannot eliminate the steps within the allowable range of $\pm 0.15^\circ$, you will need to carefully change the physical angle of the marking head/laser assembly in relation to part movement. Continue fine-tuning the Banner Tracking Angle Adjustment until all three lines in the setup file are solid, straight lines as demonstrated by line “F” in Figure 6.

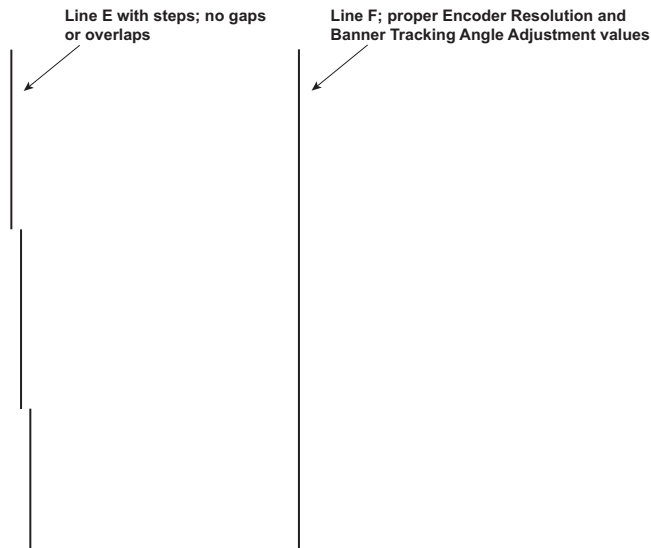

Figure 6 Illustration of line showing “stair steps” between Banner Windows

Optimize the marking method

The speed of banner tracking will vary depending on the type of objects in the mark file and the mark mode selected—WinMark control mode or Stand-alone control mode. In Stand-alone control mode (where the .mkh mark file resides in the head’s Filestore or on a network share), marks are generally quicker, especially when stroke fonts are used. If the banner tracking file contains TrueType-style fonts, WinMark control mode is generally faster.

Line speed can also be affected by the Banner Window Interval property. Best results are obtained experimentally by increasing or decreasing Banner Window Interval values until fastest line speeds are consistently achieved.

For further information, contact SYNRAD at 1.800.796.7231; outside the U.S., dial +1.425.349.3500 or send an email to: support@synrad.com.